



**R<sup>4</sup>**<sup>TM</sup>  Red  
Round  
Rotary  
Reliable

Electric Actuator

## RUGGED ELECTRIC ACTUATOR FOR ROTARY VALVES

300 TO 6,500 LB-IN OUTPUT TORQUE

Bray Controls' years of proven success in electric actuation, combined with innovative engineering, has produced the R4.™ The R4 features on-off or modulating control.

This red, round electric actuator for rotary valves delivers highly reliable service.



Bray's unique, customer-friendly designed Control Center has many advantages over present industry standards including:

- UL, CSA and CE certification of most units
- Ease of customer field wiring directly to the terminal strip without interference from other components
- Simple and unique manual override handwheel system
- Lowest profile and lightest weight actuator on the market
- Simple finger or screw driver adjustment of travel limit cams without interference from other components
- Highly visible valve status display
- Externally adjustable travel stops
- Captive housing screws

Additionally, components not requiring customer access are protected underneath the Power Center cover plate.

## LOW PROFILE, COMPACT, HIGH TORQUE DESIGN

The R4 is by far the most compact, lowest profile design of any electric actuator delivering comparable torque output. Thorough research and many years of field experience have gone into the development of this state-of-the-art actuator – *the product of the future*. This design offers the advantages of greatly reduced space requirements, lighter weight and ease of installation and maintenance when compared to other electric actuators. When mounted directly to Bray valves, the R4 is especially compact.



The Bray R4 Electric Actuator

*The R4 compared to a typical actuator, both mounted to 4" Bray valves.*

## DIRECT MOUNTING OF THE R4 ON BRAY VALVES

Bray actuators mount directly to Bray valves without using any external linkage. Field installation is simple and misalignment is minimized. For sanitary processing and outdoor applications, the Bray direct mounting system reduces the possibility of contamination buildup or corrosion between the valve and actuator. The mounting pattern complies with ISO 5211 and VDI/VDE 3845 (NAMUR recommendations). The R4 can be mounted and operated in any position. Standard rotation is 90° reversible. Bray can provide linkages for mounting the R4 to other devices requiring 90° rotation. Please consult the Bray factory for further information.

## EXTERIOR FEATURES

### EXPLOSION PROOF ENCLOSURE

The R4 waterproof/explosion proof unit is UL NEMA 4,4x,7&9 listed and certified to specifications for hazardous locations. This rugged, heavy duty housing contains precision machined bores and flanges to meet flame path requirements. The valve position indicator is viewed from behind a sodium glass explosion proof window. This unit is currently available with 800 to 2,000 lb.-in. output torque, continuous or intermittent duty.



### MECHANICAL TRAVEL STOPS

Stainless steel mechanical travel stops permit precise field adjustment of actuator movement to specific degrees of rotation. The travel stops are located outside the base for easy readjustment without removing the cover. Stainless steel lock nuts with O-ring seals hold the travel stops securely in place. The travel stops are normally set at the factory to allow 0° and 90° travel.



*R4 manual override handwheel with optional spinner.*

### ENCLOSURE (A)

The R<sup>4</sup> waterproof unit is UL NEMA 4, 4x listed. Die-cast aluminum cover and base are high-quality polyester powder coated for exceptional corrosion, wear, impact and ultra-violet resistance. Potential leak paths are eliminated since the indicator shaft does not protrude through the enclosure.

### MANUAL OVERRIDE (B)

A manual override handwheel is standard on all models to rotate the valve without electrical power. A yellow caution stripe around the handwheel hub indicates the handwheel is engaged for manual operation.

### CAPTIVE COVER BOLTS (C)

The cover is attached to the base by stainless steel bolts. When the cover is removed the bolts are held captive in the cover. This prevents time consuming problems caused from lost or misplaced bolts.

### VALVE STATUS DISPLAY (D)

The R<sup>4</sup> features a highly visible valve status display. Prominently labeled and color coded – yellow for open, red for closed – the display indicates valve position through the full range of travel. The display can be seen from almost any angle. Made of high impact, heat and chemical resistant clear polycarbonate, this display withstands caustic washdown and offers excellent corrosion protection.

**ELECTRICAL CABLE CONNECTIONS (E) (Optional)** A multi-pin, watertight cable receptacle offers full compatibility with today's industrial wiring systems. Factory pre-wiring prevents errors and allows quick-connect field installation. Cordsets with connection/flying leads or extension cords with connections on both ends can plug directly into the receptacle.



### CONDUIT ENTRIES (F)

The R<sup>4</sup> features two conduit connections in either NPT or metric threads. One entry is for power, one for control wiring.

### PILOT DRILLED HOLES FOR LOCAL CONTROL STATION MOUNTING (G)

The conduit entry panel has four holes which may be easily tapped for the installation of optional local Control Station.



## CLEAN AND EASY ACCESS TO ALL FIELD WIRING AND ADJUSTMENTS

Bray has specifically engineered the R<sup>4</sup> Control Center for customer-friendly convenience. Designed like a junction box, the R<sup>4</sup> offers by far the easiest access to terminal block wiring, cam adjustments and switch installation. Accessories are easily added, either before installation or after installation. Therefore, the time required for field start-up and adjustment is greatly reduced, and maintenance

can be performed with assured ease and safety.

Bray's unique design, modular system of components and accessories, and innovative features combine to best meet today's industrial requirements.

# R<sup>4</sup><sup>TM</sup>

## TORQUE LIMITING SWITCHING SYSTEM (Optional)

The torque limiting switching system consists of two SPDT mechanical switches and two factory calibrated adjusting screws. The green screw adjusts the torque limit in the open direction, and the red screw adjusts the torque limit in the closed direction. The switches independently respond to predetermined loads in both the open and closed travel directions by sensing the movement of the worm shaft, and interrupting the electrical power to the motor. The switches operate at any point of actuator travel.



*Torque Limit Switches shown with mounting bracket sectioned for clarity.*

## R<sup>4</sup> APPLICATIONS

The R<sup>4</sup> is the ideal choice for process control applications involving:

- Automation and computer systems
- Butterfly, ball, plug and other rotary valves
- Dampers, switches, safety and flow-control devices
- Machine and fixture indexing
- Hostile environments demanding excellent moisture, chemical and corrosion resistance
- Long service life and rugged reliability

## INDUSTRIES

Bray's R<sup>4</sup> Electric Actuators are used in a wide range of industries world wide, including:

Chemical, Pharmaceutical, Petroleum Refining and Oilfield, Microelectronics, Pulp and Paper, Water and Waste Water Treatment, Brewing, Food Processing, Beverages, Power, Marine, Mining, Textile and HVAC.

## CONTROL CENTER FEATURES

### TRAVEL LIMIT SPDT SWITCHES (A)

Bray has provided two SPDT switches as standard. These durable, high quality switches are mechanically isolated and electrically independent. The dedicated circuits eliminate any voltage crossover between the switches. This switch combination is used for both open and closed positions of the valve and requires only one cam for each direction of valve travel. Bray's design provides synchronicity between motor control and position display. Switches are easily accessible without interference from other components. Each switch is marked with open or close labels and the cams are color coded, green for open and red for close, eliminating the possibility of making wrong adjustments of travel limits or field wiring errors.

### AUXILIARY SWITCHES (Optional)

Independent dry-contact SPDT switches are available to indicate travel position to remote customer control systems.

### AUTOMATIC POWER CUTOUT SWITCH (B)

The R<sup>4</sup> is supplied with a SPDT mechanical switch which cuts power to the motor when the handwheel is engaged for manual operation. This switch also functions as a safety emergency shutdown device that immediately stops the actuator motor even if electrical power is still being applied to the motor.

### CERTIFICATIONS / APPROVALS

Bray has gained UL, CSA and CE certifications on most intermittent and continuous duty actuators. These certifications insure that the R<sup>4</sup> has been designed to the highest quality requirements and most stringent safety standards worldwide. Substantial resources have been invested to assure our customers that the R<sup>4</sup> is the best actuator on the market and will remain so.





**CAMS / CAM ADJUSTMENT (C)**  
 Bray's patented cam design is an outstanding feature of the R<sup>4</sup>. Cams for each switch are *infinitely* adjustable by finger touch or screwdriver with no special tools needed. The adjustment knobs rotate the specially formed cams.

Each cam is color coded – the red adjustment knob controls the red cam (close position), and the green knob controls the green cam (open position). Standard factory setting allows 90° travel between open and closed positions.

**TERMINAL BLOCK (D)**  
 The actuator switches are pre-wired to a terminal block. The block has been designed for ease of customer wiring without interference from other components and features clearly marked terminal numbers. The block has been placed near the two conduit entries with ample room for running wire leads. A wiring diagram is included inside the cover for easy reference. The ground wire screw (E) is plated green and positioned for easy access. With some optional features Bray installs a second terminal block for Bray factory wiring and customer field wiring of additional limit switches.

**O-RING SEAL FOR WATERTIGHT ENCLOSURE (F)**  
 The large seal between the cover and base provides a waterproof seal and prevents internal corrosion. The Bray R<sup>4</sup> O-ring seal is the best design for watertight enclosures and is far superior to commonly used gaskets.



**HEATER (G) (Optional)**  
 Pre-wired to the terminal block, a self-regulating heater prevents condensation from collecting inside the actuator, which could cause damage to the electrical components. The heater is mounted below the switch plate. Heaters are ideal for use in applications with extremely wide temperature or humidity ranges.

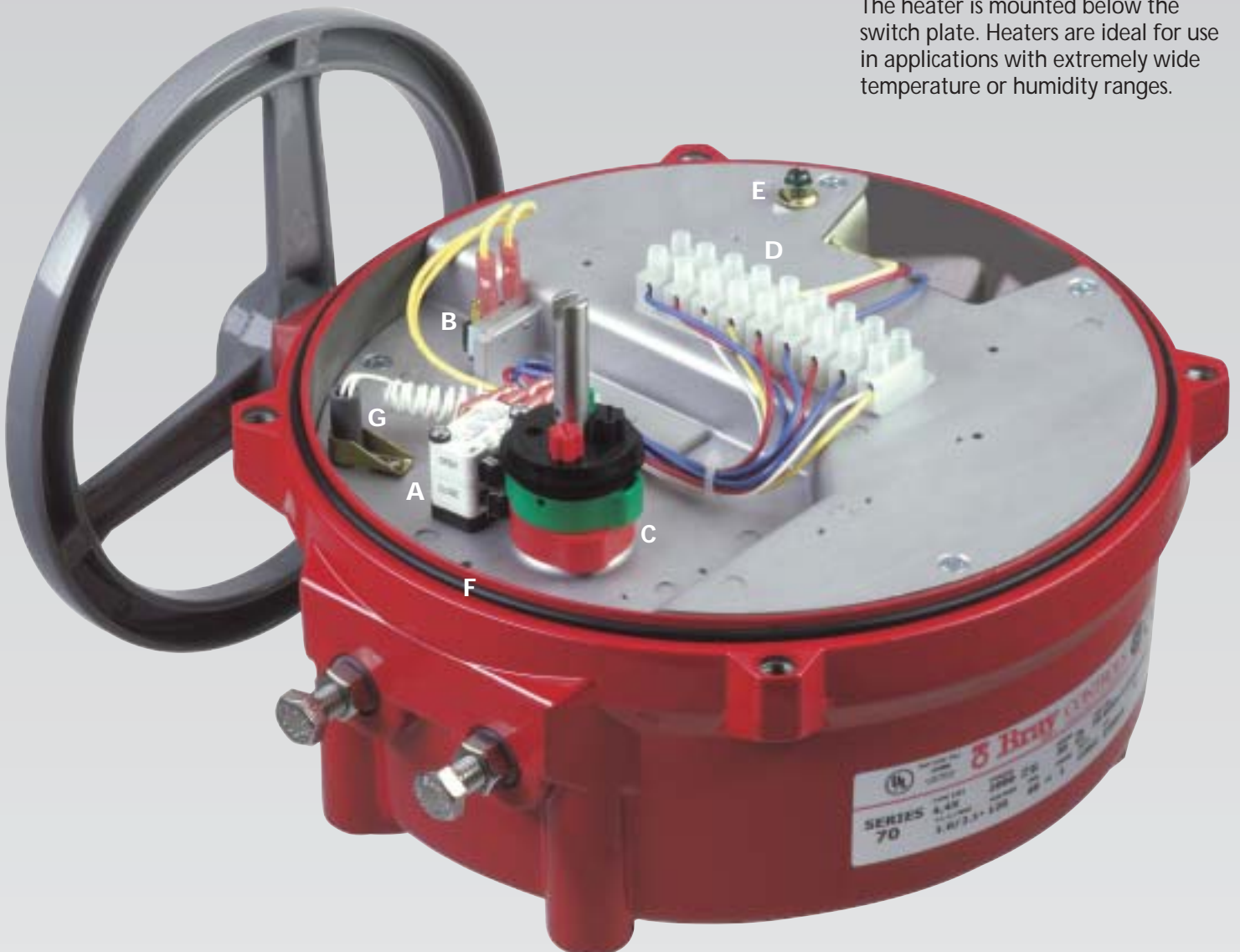

Bray designed the R<sup>4</sup> to completely separate the Control Center from the Power Center. The Power Center, located in the actuator base, consists of motor, gear train, capacitor, output drive and heater. This design protects the power drive system as each component has been engineered to require no customer servicing. The Power Center components have been uniquely configured to maintain the extremely low profile of the R<sup>4</sup>.

## POWER CENTER FEATURES

**MOTOR (A), CAPACITOR (B), SPUR GEAR TRAIN (C) AND WORM GEAR (H)** The R<sup>4</sup> has a 120 or 220 VAC single phase permanent split-capacitor reversible induction motor. The motor features a built-in thermal overload protector of a bi-metallic strip

in the windings set at 275°F (135°C) with automatic reset. The heavy-duty spur gear train is composed of precision cut, multi-staged gears and shafts. The gears and shafts are heat treated high alloy steel and will withstand locked rotor conditions. The spur gear train is permanently lubricated at the factory. This gear train drives the worm shaft which in turn drives the segmented worm gear output shaft.



Above photograph is a sectional view of the manual override assembly with override disengaged. Photograph below shows manual override engaged.

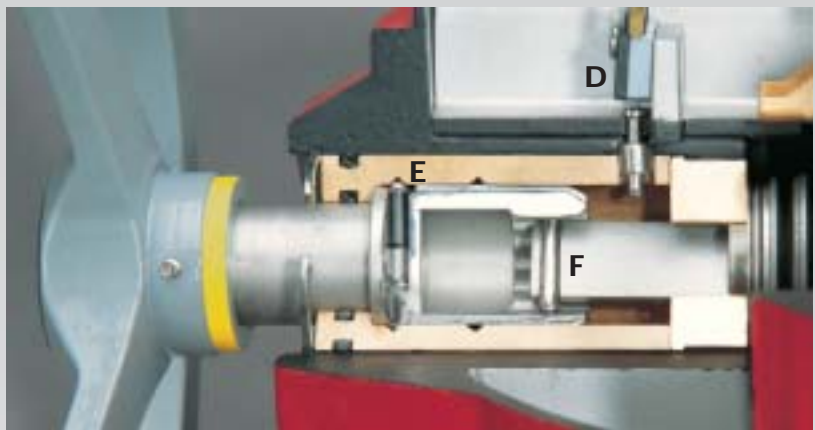

### MANUAL OVERRIDE HANDWHEEL ASSEMBLY

- Pull to engage for manual operation.
- Rotate handwheel to position valve.
- Push to disengage for power operation.

A simple pull engages the handwheel for manual operation. The Bray manual override system ensures positive and fast manual operation without the use of extra tools or levers. When the handwheel is engaged, the electrical

power to the motor is cut off by means of the Automatic Power Cutout Switch (D). When engaged, the manual override shaft is held in position by a Ball Detent (E). The Ball Detent also holds the shaft in position when the handwheel is pushed in to disengage the override. The Drive Pin (F) engages and disengages the manual override shaft from the worm and segmented worm gear output shaft. When the handwheel is pushed or pulled, the drive pin smoothly engages the worm shaft.



**SELF-LOCKING  
OUTPUT DRIVE ASSEMBLY**

The output drive assembly features a self-locking worm and worm gear drive which holds the valve in the desired position without the need for electro-mechanical braking systems. The worm shaft directly drives the worm gear. The Worm (G) is made of chrome-moly steel and the segmented Worm Gear (H) is a precision machined aluminum bronze casting. The worm gear and Output Shaft (I) are one part. The output shaft is the driving member that positions the valve. The worm gear drives the valve status display shaft which operates the infinitely adjustable cams to limit the electrical travel of the actuator.

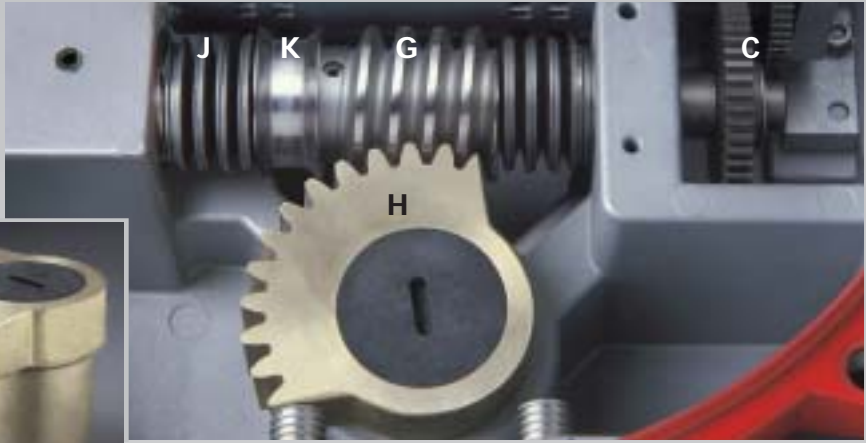

**MECHANICAL TORQUE  
LIMITING SYSTEM  
(Optional)**

The mechanical torque limiting system consists of a Worm Shaft, a Worm (G), a set of Torque Disc Springs (J) and a Shaft Groove (K) for torque limiting switches. The torque disc springs, located on each side of the worm, resist the linear movement of the worm shaft. The worm

shaft is driven against the torque disc springs in response to output torque. The shaft groove actuates the torque limiting switches, located above in the Control Center, to start and stop the motor. (Please refer to the Control Center section on page 4 for description of the Torque Limiting Switching System). The precisely controlled movement of this system is the main torque limiting element of the R<sup>4</sup>.

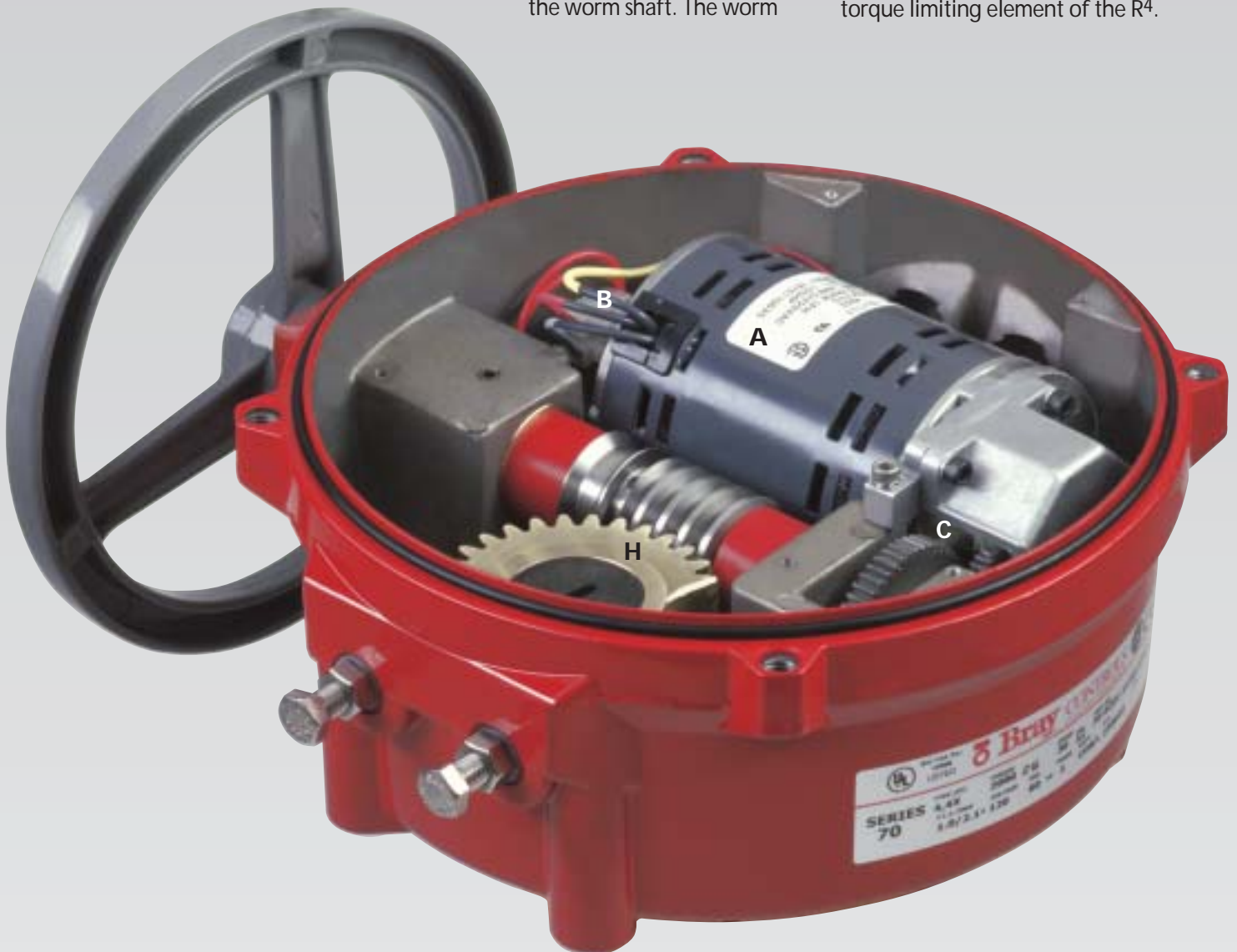

## MODULATING ACTUATOR FOR PRECISION CONTROL OF VALVE POSITION

The Bray R4 Electric Actuator can be equipped with a Servo for precise control of valve position. The Servo consists of a microprocessor controlled circuit board and a feedback potentiometer assembly, which both fit entirely within the standard R4 actuator housing. The circuit board has terminal blocks for customer field wiring, and other terminals for internal connections to the actuator components. The feedback potentiometer is driven by a gearset connected to the actuator output drive. Also available are Servos capable of serial bus communication, such as DeviceNet.



## COMMAND CENTER OPTIONS

### SERVO PLUS II OPERATION

The Servo Plus II can be configured by the factory or the customer to accept several types of input signals, such as 4-20 mA DC, 0-10 VDC, 0-5 VDC or potentiometer control. Each terminal connection and indicator is clearly labeled to simplify field wiring and operation. The input signal electronically represents the *desired* actuator position, and the internal feedback potentiometer signal electronically represents the *actual* actuator position. The



Feedback Potentiometer Gear

microprocessor constantly compares the two signals, and if a difference is detected, drives the actuator in the proper direction until the signals are equal. When a balance is reached, the microprocessor turns off the actuator motor. The worm gear then mechanically holds the valve in the desired position until the input signal is changed again.

### SPEED CONTROL

Adjustments are configurable for both open and closed speed control of the actuator motor. In addition, an approach control circuit senses when the actuator is about to reach the desired valve position, and pulses the motor to avoid overshooting the setpoint.

### POTENTIOMETER CALIBRATION

Calibration of the feedback potentiometer is done through a unique gear arrangement that is easily accessible and eliminates the need of any special tools. A simple adjustment of Bray's patented cam drive aligns the potentiometer gear as easily as a travel cam.

### SERVO PLUS II FEATURES / SPECIFICATIONS

**Note: Servo is available for modulating service – continuous duty actuators only.**

**Note:** "Standard" is the way the Servo is set at the factory.

"Configurable" means the customer, or the factory, can modify the Servo with the Configuration Tool Software and cable.

POWER INPUT:	85-265 VAC, 50/60 Hz (power must match motor)
POWER CONSUMPTION:	2 Watts (not including actuator power)
INPUT SIGNAL:	Standard: 4-20 mA DC into 250 Ohm Configurable: 0-10 VDC, 2-10 VDC, 135 Ohm or greater potentiometer
CALIBRATION:	Single Button Autocalibration, Load Factory Defaults
INDICATORS:	Power: Green LED Status: Flashing Red / Green LED Motor: Red LED (Close), Green LED (Open)
CONTROL MODES:	Standard: Full Range Configurable: Split Range 0-50%, Split Range 50-100%, Reverse Acting
FAIL POSITION : (Loss of Input Signal)	Standard: Fail Closed Configurable: Any position between 0%-100%, including Fail in Last Position, Fail Open or Fail Closed
CONTROL CHARACTERISTIC:	Linear
DUTY CYCLE:	100%
INTERNAL FEEDBACK:	10k Ohm Potentiometer, gear driven
RETRANSMISSION OUTPUT:	Standard: 4-20 mA DC Configurable: 0-20 mA DC, 0-10 VDC, 2-10 VDC Power Feedback Output is designed to drive an isolated 200 – 1k Ohm resistive load.
SPEED CONTROL:	Standard: Speed Control is Disabled Configurable: Bidirectional – Independent Open and Close adjustment for On Time, Off Time, Speed Control Starting Position and Speed Control Stop Position

### FEEDBACK POTENTIOMETER

The feedback potentiometer gear has an over-torque shift engagement which operates if the limits of the active region of the potentiometer are exceeded. This situation can occur when the manual override handwheel is turned past 90° or below 0° travel. The potentiometer gear always remains engaged with the drive gear, but shifts on its shaft to prevent damage and maintain proper alignment.

### VOLTAGE SPIKE PROTECTION

Voltage spikes that can damage electrical equipment are very common in industrial locations. Large voltage spikes can be caused by switching power loads, such as large motor drives, at the customer location. The output stage TRIACs of the Servo are protected

against damage from voltage spikes by a special combination of

- limit switch circuitry
- metal oxide varistor (MOV) for transient voltage suppression
- zero crossing detection

### DEVICENET SERVO

Bray also offers the Series 70 with the most advanced serial bus communication Servo on the market. The Bray DeviceNet Servo is fully ODVA (Open DeviceNet Vendor Association) compliant. Benefits include greatly simplified field wiring and installation, advanced control and diagnostics in real-time from a remote location, and full network integration. Please contact your Bray representative for more information.

### CONTROL STATION (Optional)

Bray has designed a manual local electrical control station that flush



*Control Station*

mounts directly to the R<sup>4</sup>. The Control Station features:

- a local-off-remote control switch
- an open-stop-close switch
- two lights which locally indicate open and closed valve position

The cover plate can be rotated in any 90° increment, allowing the customer to operate and view the station with ease. The enclosure is aluminum and weatherproof (NEMA 4, 4X, IP 65). Additionally, the control station has captive cover bolts and two input ports available in the following thread connections: 3/4" NPT or M25. Two different multi-pin, watertight electrical cable connections are also available.

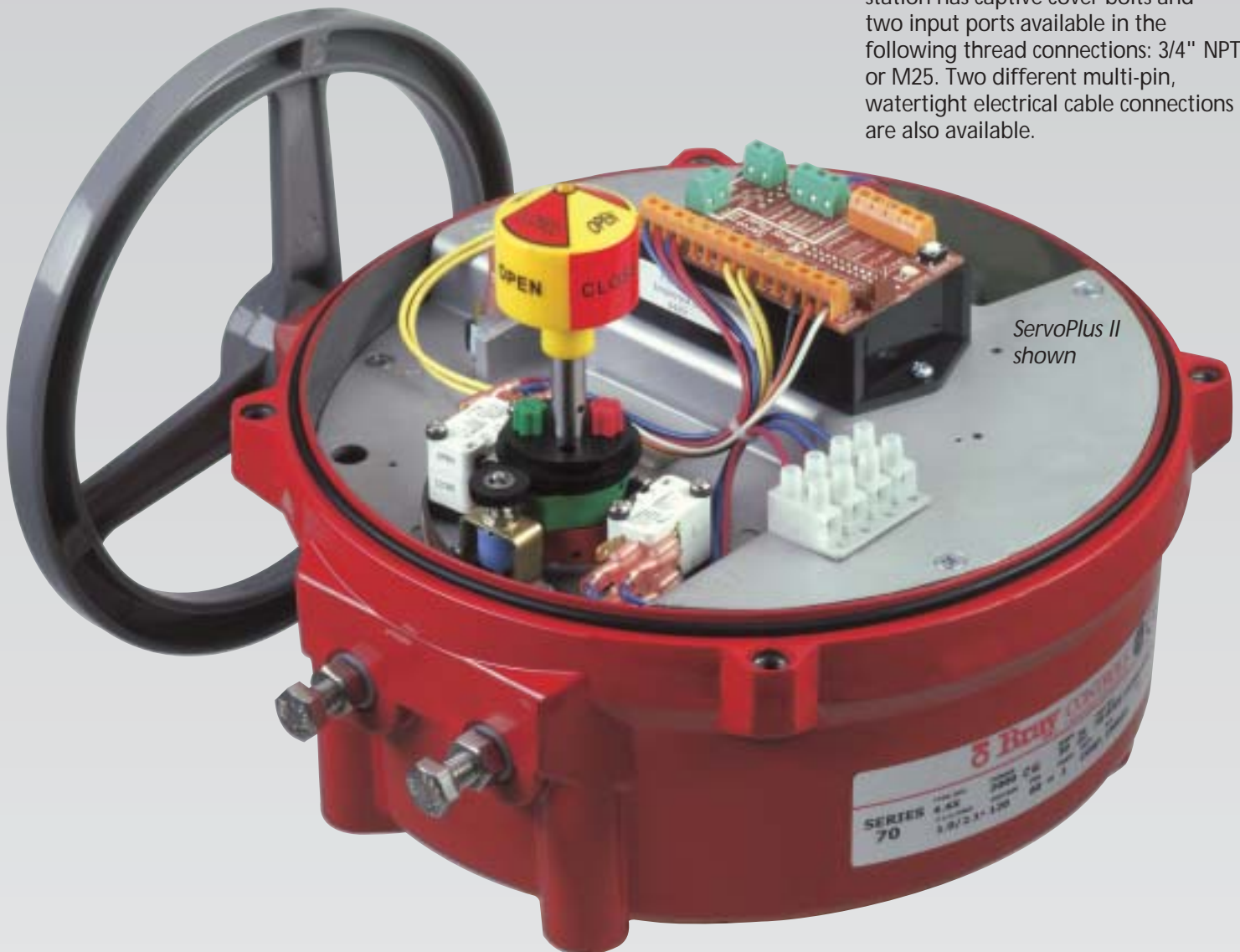

*ServoPlus II shown*

## WATERPROOF ENCLOSURE

Actuator Series	A	B	C	D	E	F	G	H	J	K (UNC) x B.C.	M (UNC) x B.C.	N	P	Q	Weight lbs [kgs]
S70-003 S70-005	7.5 [191]	5.6 [142]	3.0 [76]	5.1 [130]	1.9 [48]	1.94 [49.3]	.19 [4.8]	1/2 ‡	2.0 [51]	5/16-18 x ø2.76	—	.75 [19]	.51 [13]	1.75 [44]	12 [6]
S70-008 S70-012 S70-020	10.1 [257]	7.8 [198]	3.7 [94]	6.5 [165]	2.5 [64]	2.69 [68.3]	.56 [14.2]	3/4 ‡	2.6 [66]	5/16-18 x ø2.76	1/2-13 x ø4.92	1.18 [30]	.87 [22]	2.20 [56]	28 [13]
S70-030 S70-050 S70-065	12.1 [307]	9.5 [241]	5.6 [142]	7.2 [183]	2.9 [74]	3.19 [81]	.56 [14.2]	3/4 ‡	3.1 [79]	1/2-13 x ø4.92	3/4-10 x ø6.50	See Detail A			48 [22]

## WATERPROOF / EXPLOSION PROOF ENCLOSURE

S70-708 S70-712 S70-720	12.5 [317]	8.0 [203]	3.7 [94]	7.2 [183]	2.5 [64]	2.69 [68.3]	.56 [14.2]	3/4 ‡	2.6 [66]	5/16-18 x ø2.76	1/2-13 x ø4.92	1.18 [30]	.87 [22]	2.20 [56]	34 [16]
-------------------------------	---------------	--------------	-------------	--------------	-------------	----------------	---------------	----------	-------------	--------------------	-------------------	--------------	-------------	--------------	------------

### Notes:

- 1) Dimensions are in Inches, [Millimeters in brackets].
- 2) Handwheel Spinner shown in drawing is available as an option.
- 3) K & M Dimensions are also available in M8, M12, and M16.
- 4) N Dimension is also available with Double Square (Star) drive.

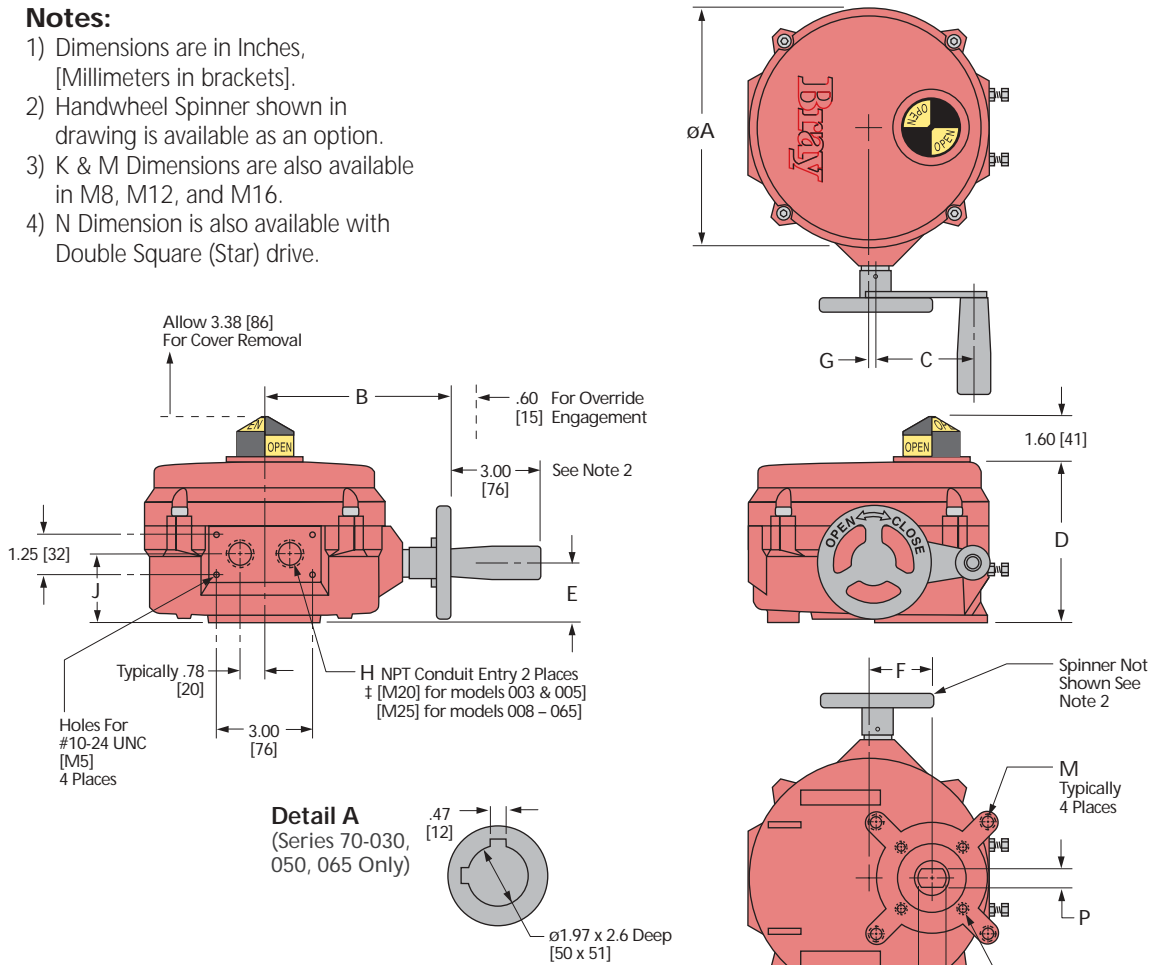

## WATERPROOF / EXPLOSION PROOF ENCLOSURE

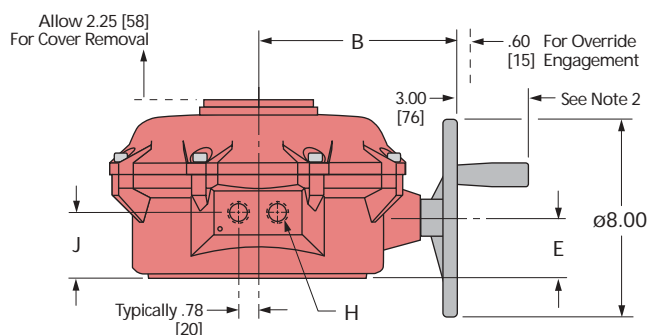

Actuator Series	Torque Output lb/in [Nm]	Single Phase Motors Current Rating (Amps) At All Speeds (locked rotor)			Speed For 90° Operation In Seconds / Total Gear Ratio						Rim Pull lbs [kgs]	Bray Valve Sizes For Direct Mounting
		VAC	Hz	Amps	On-Off Intermittent‡		Modulating Continuous‡		Manual Override			
					Optional Speeds	Standard Speeds	Optional Speeds					
S70-003	300 [34]	120	50/60	0.8	8 sec.	15 sec.	30 sec.	60 sec.	30:1	11.4 [5]	2" through 6"	
		220	50/60	0.5								1,392:1
S70-005	500 [57]	120	50/60	1.4		15 sec.	30 sec.	60 sec.	30:1	19.0 [9]	2" through 6"	
		220	50/60	0.6								2,413:1
S70-008	800 [90]	120	50/60	2.1	6 sec.	10 sec.	15 sec.	30 sec.	30:1	13.0 [6]	2" through 12"	
		220	50/60	0.9								681:1
S70-012	1200 [136]	120	50/60	2.1		10 sec.	15 sec.	30 sec.	30:1	20.0 [9]	2" through 12"	
S70-712	220	50/60	0.9	1,080:1								1,640:1
S70-020	2000 [226]	120	50/60	2.1		15 sec.	30 sec.		30:1	33.0 [15]	2" through 12"	
		220	50/60	0.9								1,640:1
S70-030	3000 [339]	120	50/60	3.0		18 sec.	30 sec.		30:1	33.0 [15]	8" through 20"	
		220	50/60	1.4								2,080:1
S70-050	5000 [565]	120	50/60	3.0		18 sec.	30 sec.		30:1	55.0 [25]	8" through 20"	
		220	50/60	1.4								2,080:1
S70-065	6500 [734]	120	50/60	3.0			30 sec.		30:1	72.0 [33]	8" through 20"	
		220	50/60	1.4								3,340:1

‡ The duty cycle for intermittent on-off operation is 25%. The continuous duty actuator with Servo is rated for 100% modulating operation.

Waterproof (NEMA 4, 4x) 120 VAC intermittent and continuous duty single phase units are UL and CSA certified. 120 & 220 VAC intermittent and continuous duty single phase units conform to CE standards and have been certified by an independent lab. Waterproof/Explosion proof (NEMA 4, 4x, 7, 9) 120 VAC intermittent and continuous duty single phase units are UL certified. Each Series 70 actuator carries all applicable agency markings.

12 VDC, 24 VDC available as an option, please consult your Bray representative or the factory.

### 3 Phase Motors

208, 230, 415, 460 and 480 V, 50/60 Hz motors are available. Size 008, 708, 012, 712, 020, 720, 030, 050 and 065 units are available with 3 Phase Motors.

## TYPICAL WIRING DIAGRAMS

**ON-OFF**  
With Optional Torque Limit Switches, Auxilliary Limit Swithes and Heater

Wiring Diagrams are For Reference Only. Do NOT use for field wiring.

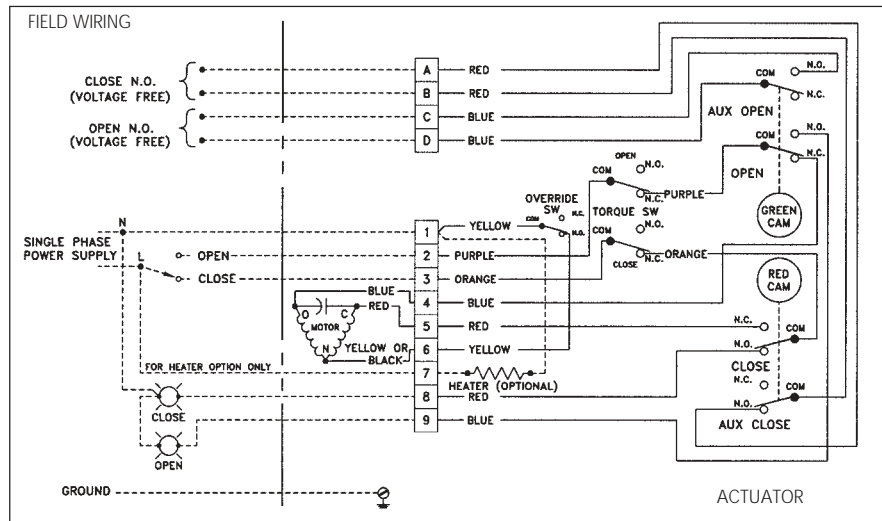

## MODULATING-Servo Plus II

With Optional Torque Limit Switches and Heater

### Notes:

- 1) Actuators are shown in closed position.
- 2) Manual Override is not engaged.
- 3) Actuators are shown with optional Torque Switches, Auxilliary Travel Switches (Not shown on Modulating Unit Diagram) and Heater
- 4) All switches are Single Pole, Double Throw.
- 5) Terminal block accepts field wiring from 12-22 AWG, 14-22 AWG for Servo.
- 6) Modulating Unit: Position Feedback Output is designed to drive an isolated 200 -1k Ohm resistive load.

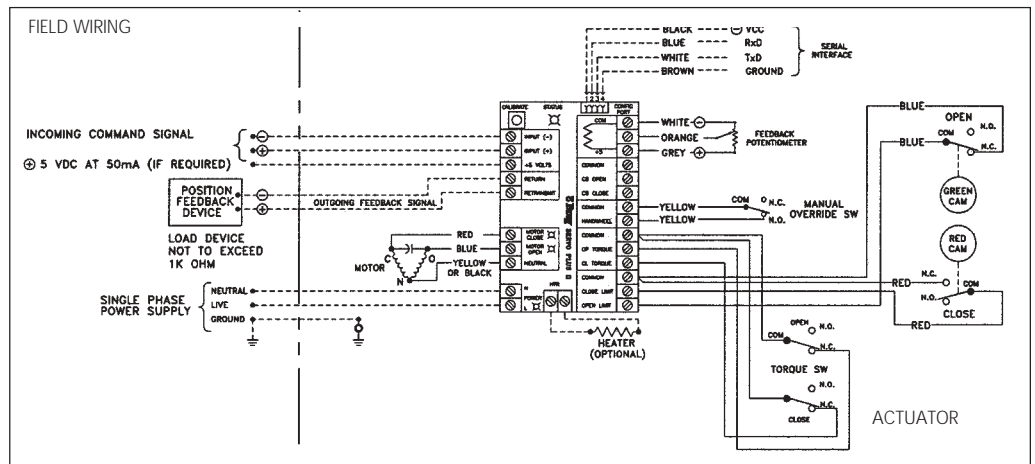

The electric actuator shall be compact and low-profile to greatly reduce space requirements. The actuator shall feature ease of access to field wiring and adjustment. The actuator shall be built to withstand line vibration and shock without failure and shall bolt directly to Bray valve mounting flanges without using brackets.

**MOTOR** A single phase permanent split-capacitor reversible motor with voltages of 120 and 220 VAC 50/60 Hz shall be standard. Motor insulation shall be Class F or better. The motor shall contain a built-in UL approved automatic reset thermal overload protector set at 275°F (135°C) embedded in motor windings. A variety of 3-Phase 50/60 Hz and DC motors shall be available upon request.

**DUTY CYCLE** The duty cycle for intermittent on-off operation shall be 25%. The continuous duty actuator with Servo shall be rated for 100% modulating operation.

**SPUR GEAR TRAIN SYSTEM** The actuator shall have a self-locking gear train consisting of a worm and worm gear output drive mechanism. The spur gear train shall have precision cut multi-staged gears which will withstand locked rotor conditions. The spur gear train shall be permanently lubricated at the factory. The gear train shall drive a chrome-moly steel worm which drives the composite aluminum bronze segmented worm gear / output shaft.

**WIRING** Actuator switches shall be pre-wired to a terminal block for ease of access and all internal wiring shall range from 12-22 AWG.

**SWITCHES** All travel switches shall be Single Pole, Double Throw, Form C type, 10A at 125/250 VAC, 1/2 A at 125 VDC, UL listed and CSA approved. Travel Limit switches shall limit actuator in both the open and closed position of valve travel.

**CAMS** Cams for each travel limit switch shall be infinitely adjustable by finger touch or screw driver, as provided by Bray's patented design.

**CONDUIT ENTRIES** All units shall have 2 conduit entries. Conduit entries for models 003 and 005 shall be either 1/2" NPT or M 20. Conduit entries for models 008 – 065 shall be either 3/4" NPT or M 25.

**MECHANICAL TRAVEL STOPS** Mechanical stainless steel travel stops shall be located outside the actuator for ease of adjustment and contain stainless steel lock nuts to hold the travel stops in place. O-rings provide waterproof seals. The travel stops shall limit the actuator movement to specific degrees of rotation.

**MANUAL OVERRIDE** All units shall be equipped with an aluminum manual override handwheel to rotate the valve without electrical power. The override assembly shall ensure positive and fast manual operation without the use of extra tools or levers.

**EMERGENCY SHUT-OFF** An automatic power cutout switch shall be provided to cut power to the motor when actuator handwheel is engaged for manual operation. This switch shall function as a safety emergency shutdown device.

**ENCLOSURE** The die-cast aluminum enclosure shall be certified to UL, CSA & CE waterproof standards (NEMA 4, 4X, IP 65). Cover shall be polyester powder coated for exceptional corrosion, wear, impact and UV resistance. The enclosure shall have captive cover bolts, therefore preventing time consuming problems due to lost or misplaced bolts. A UL listed waterproof / explosion proof enclosure (NEMA 4, 4X, 7, 9) shall be available.

**VALVE STATUS DISPLAY** The actuator shall have a highly visible clear polycarbonate display prominently labeled and color coded to indicate valve position throughout the full range of travel.

**TEMPERATURE RATING** Actuators shall be designed for temperature ranges of -40°F (-40°C) to +150°F (65°C).

### OPTIONAL EQUIPMENT

The actuator shall be designed to include any of the following accessories as an option.

**TORQUE LIMITING SYSTEM** with 2 SPDT mechanical switches and 2 factory calibrated adjusting screws – the green adjusts the limit in

the open direction, the red adjusts the limit in the closed direction. The worm shaft shall be driven against the torque disc springs in response to the output torque. The switches contact the worm shaft groove in response to predetermined loads and interrupt the electrical power to the motor. Switches shall operate at any point of actuator travel.

**HEATER** with self-regulating temperature control to prevent condensation buildup. The heater shall be pre-wired to the terminal block. Rated output is 15 W at 120 or 220 VAC.

**SERVO** A microprocessor controlled Servo shall be available for precise modulating control of valve position in response to an analog input signal. The Servo shall have an analog output signal proportional to actual valve position as standard. This analog signal shall be configurable to either current or voltage output. The Servo shall have a specially engaged potentiometer gear which prevents damage due to over rotation. The Servo shall have voltage spike protection on all input terminals. Adjustments shall be provided for both open and closed Speed Control of the actuator. Input Signals: 4-20 mA DC into 250 Ohm, 0-10 VDC, 0-5 VDC, 135 Ohm or greater potentiometer. 10k Ohm Potentiometer shall be used for internal feedback.

DeviceNet Servos shall be available.

**CONTROL STATION** for manual local electrical operation of the actuator. The Control Station shall flush mount to the actuator and feature a local / off / remote control switch, an open-stop-close switch, and two lights which locally indicate open and closed valve position. The enclosure shall be aluminum and waterproof (NEMA 4, 4X, IP 65).



The Bray R4™ Electric Actuator – Series 70-005, 065 and 020.

DISTRIBUTOR



All statements, technical information, and recommendations in this bulletin are for general use only. Consult Bray representatives or factory for the specific requirements and material selection for your intended application. The right to change or modify product design or product without prior notice is reserved.

United States patent number 5,305,781. Other patents applied for worldwide.



A Division of BRAY INTERNATIONAL, Inc.  
13333 Westland East Blvd. Houston, Texas 77041  
281.894.5454 FAX 281.894.9499 www.bray.com

Bray® is a registered trademark of BRAY INTERNATIONAL, Inc.  
© 2004 Bray International. All rights reserved. B-1016 7/04