

FIELDVUE® DVC6000 Series Digital Valve Controllers

FIELDVUE® DVC6000 Series digital valve controllers (figures 1 and 2) are communicating, microprocessor-based current-to-pneumatic instruments. In addition to the traditional function of converting a current signal to a valve-position pressure signal, DVC6000 Series digital valve controllers, using HART® communications protocol, give easy access to information critical to process operation. This can be done using a Model 375 Field Communicator at the valve or at a field junction box, or by using a personal computer or a system console within the control room. Using HART communication protocol, information can be integrated into a control system or received on a single loop basis.

DVC6000 Series digital valve controllers can be used on single- or double-acting actuators. The digital valve controller receives feedback of the valve travel position plus supply and actuator pneumatic pressure. This allows the instrument to diagnose not only itself, but also the valve and actuator to which it is mounted. This provides you with very cost effective maintenance information, so that required maintenance can be performed on the instrument and valve when there really is a need.

Wiring is economical because DVC6000 Series digital valve controllers use two-wire 4 to 20 mA loop power. This provides for low cost replacement of existing analog instrumentation. The DVC6000 Series digital valve controller's two-wire design avoids the high cost of running separate power and signal wiring.



W7957-1 / IL

Figure 1. Type DVC6010 Digital Valve Controller Mounted on a Sliding-Stem Valve Actuator



W7960-1 / IL

Figure 2. Type DVC6010 Digital Valve Controller Mounted on Type 585C Piston Actuator



Specifications

Available Configurations

Valve-Mounted Instrument.

DVC6010: Sliding-stem applications

DVC6020: Rotary applications and long-stroke sliding-stem applications

DVC6030: Quarter-turn rotary applications

Remote-Mounted Instrument⁽¹⁾.

DVC6005: Base unit for 2-inch pipestand or wall mounting

DVC6015: Feedback unit for sliding-stem applications

DVC6025: Feedback unit for rotary or long-stroke sliding-stem applications

DVC6035: Feedback unit for quarter-turn rotary applications

DVC6000 Series digital valve controllers can be mounted on Fisher and other manufacturers rotary and sliding-stem actuators.

Input Signal⁽²⁾

Point-to-Point:

Analog Input Signal: 4-20 mA dc, nominal; split ranging available

Minimum Voltage Available at Instrument Terminals must be 10.5 volts dc for analog control, 11 volts dc for HART communication (see instrument instruction manual for details)

Minimum Control Current: 4.0 mA

Minimum Current w/o Microprocessor Restart: 3.5 mA

Maximum Voltage: 30 volts dc

Overcurrent Protection: Input circuitry limits current to prevent internal damage

Reverse Polarity Protection: No damage occurs from reversal of loop current

Multi-drop:

Instrument Power: 11 to 30 volts dc at approximately 8 mA

Reverse Polarity Protection: No damage occurs from reversal of loop current

Output Signal⁽²⁾

Pneumatic signal as required by the actuator, up to 95% of supply pressure

Minimum Span: 0.4 bar (6 psig)

Maximum Span: 9.5 bar (140 psig)

Action: ■ Double, ■ Single Direct, and ■ Single Reverse

Supply Pressure

Minimum Recommended: 0.3 bar (5 psig) higher than maximum actuator requirements

Maximum: 10.0 bar (145 psig) or maximum pressure rating of the actuator, whichever is lower

Steady-State Air Consumption⁽¹⁾⁽²⁾⁽⁴⁾⁽⁷⁾

Standard Relay: At 1.4 bar (20 psig) supply pressure: Less than 0.4 normal m³/hr (14 scfh)

At 5.5 bar (80 psig) supply pressure: Less than 1.4 normal m³/hr (49 scfh)

Low Bleed Relay: At 1.4 bar (20 psig) supply pressure: Average value 0.056 normal m³/hr (2.1 scfh)

At 5.5 bar (80 psig) supply pressure: Average value 0.184 normal m³/hr (6.9 scfh)

Maximum Output Capacity⁽¹⁾⁽⁴⁾

At 1.4 bar (20 psig) supply pressure: 10.6 normal m³/hr (375 scfh)

At 5.5 bar (80 psig) supply pressure: 31.1 normal m³/hr (1100 scfh)

Independent Linearity⁽²⁾⁽⁵⁾

±0.50% of output span

Electromagnetic Interference (EMI)⁽⁶⁾

Tested per IEC 61326-1 (Edition 1.1). Meets emission levels for Class A equipment (industrial locations) and Class B equipment (domestic locations). Meets immunity requirements for industrial locations (Table A.1). Immunity performance is shown in table 1.

Electrical Classification⁽⁶⁾

Hazardous Area: Explosion-proof, intrinsically safe, Division 2, and flameproof constructions are available to CSA, FM, CENELEC, and SAA standards. Refer to hazardous area classification bulletins 9.2:001 series and 9.2:002. Pollution Degree 2, Overvoltage Category III per ANSI/ISA-82.02.01 (IEC 61010-1 Mod)

Electrical Housing: Meets NEMA 4X, CSA Type 4X, IEC 60529 IP66

(continued)

Specifications (continued)

IEC 61010 Compliance Requirements
(Valve-Mounted Instruments Only)

Power Source: The loop current must be derived from a separated extra-low voltage (SELV) power source

Environmental Conditions: Installation Category I

Connections

Supply Pressure: 1/4-inch NPT female and integral pad for mounting 67CFR regulator

Output Pressure: 1/4-inch NPT female

Tubing: 3/8-inch metal, recommended

Vent (pipe-away): 3/8-inch NPT female

Electrical: 1/2-inch NPT female conduit connection, M20 adaptor optional

Operating Ambient Temperature Limits

-40 to 80°C (-40 to 176°F) for most approved valve-mounted instruments and Type DVC6005 base unit

-40 to 125°C (-40 to 257°F) for remote-mounted feedback unit.

-52 to 80°C (-62 to 176°F) for valve-mounted instruments utilizing the Extreme Temperature option (fluorosilicone elastomers)

See the Hazardous Area bulletins for specific ambient temperature limits of units approved for operation in hazardous areas.

Construction Materials

Housing, module base and terminal box:
ASTM B85 A03600 low copper aluminum alloy (standard)

CF8M (cast 316 stainless steel) (optional for valve-mounted instruments only)

Cover: Valox

Elastomers

Standard: Nitrile

Optional: Fluorosilicone

Stem Travel

DVC6010, DVC6015: 0 to 102 mm (4 inches) maximum

0 to 9.5 mm (3/8 inches) minimum

DVC6020, DVC6025: 0 to 606 mm (23-7/8 inches) maximum

Shaft Rotation (DVC6020, DVC6025, DVC6030 and DVC6035)

0 to 50 degrees minimum

0 to 90 degrees maximum

Mounting

Designed for direct actuator mounting or remote pipestand or wall mounting. For weatherproof housing capability, the instrument must be mounted upright to allow the vent to drain.

Weight

Valve-Mounted Instruments.

Aluminum: 3.5 kg (7.7 lbs)

Stainless steel: 7.7 kg (17 lbs)

Remote-Mounted Instruments.

DVC6005 Base Unit: 4.1 kg (9 lbs)

DVC6015 Feedback Unit: 1.3 kg (2.9 lbs)

DVC6025 Feedback Unit: 1.4 kg (3.1 lbs)

DVC6035 Feedback Unit: 0.9 kg (2.0 lbs)

Options

- Supply and output pressure gauges or
- Tire valves,
- Integral mounted filter regulator,
- Stainless steel housing, module base and terminal box (valve-mounted instruments only),
- Low-Bleed Relay,
- Extreme Temperature

1. 3-conductor shielded cable, 22 AWG minimum wire size, is recommended for connection between base unit and feedback unit. Pneumatic tubing between base unit output connection and actuator has been tested to 15 meters (50 feet) maximum without performance degradation.
 2. These terms are defined in ISA Standard S51.1.
 3. Normal m³/hr--Normal cubic meters per hour at 0°C and 1.01325 bar, absolute; Scfh--Standard cubic feet per hour at 60°F and 14.7 psia.
 4. Values at 1.4 bar (20 psig) based on a single-acting direct relay; values at 5.5 bar (80 psig) based on double-acting relay.
 5. Not applicable for Type DVC6020 digital valve controllers in long-stroke applications or remote-mounted Type DVC6005 digital valve controllers with long pneumatic tubing lengths.
 6. Approvals for remote-mounted units are pending.
 7. The Low Bleed Relay is offered as standard relay for DVC6000 ESD tier, used for On/Off applications.

Features

● **Improved Control**—Two-way digital communications give you current valve conditions. You can rely on this real-time information to make sound process management decisions. By analyzing valve dynamics through AMS ValveLink Software, you can identify control areas needing improvement

and maintain a high level of system performance.

● **Environmental Protection**—You can avoid additional field wiring by connecting a leak detector or limit switch to the auxiliary terminals in the DVC6000 Series digital valve controller. In this way, the instrument will issue an alert if limits are exceeded.

Table 1. Immunity Performance

Port	Phenomenon	Basic Standard	Performance Criteria ⁽¹⁾	
			Point-to-Point Mode	Multi-drop Mode
Enclosure	Electrostatic discharge (ESD)	IEC 61000-4-2	A ⁽²⁾	A
	Radiated EM field	IEC 61000-4-3	A	A
	Rated power frequency magnetic field	IEC 61000-4-8	A	A
I/O signal/control	Burst	IEC 61000-4-4	A ⁽²⁾	A
	Surge	IEC 61000-4-5	A ⁽²⁾	A
	Conducted RF	IEC 61000-4-6	A	A

1. A = No degradation during testing. B = Temporary degradation during testing, but is self-recovering.
 2. Excluding auxiliary switch function, which meets Performance Criteria B.

- **Enhanced Safety**—You can check instrument and valve operation and keep the process running smoothly and safely from a remote location. Access is possible at a field junction box, marshalling panel, or within the safety of the control room using either a 375 Field Communicator, a notebook PC, or a system workstation. Your exposure to hazardous environments is minimized and you can avoid having to access hard-to-reach valve locations.

- **Hardware Savings**—DVC6000 Series digital valve controllers, when used in an integrated system, allow you to realize significant hardware and installation cost savings by replacing other devices in the process loop, such as positioners and limit switches, with a FIELDVUE digital valve controller.

- **Built to Survive**—Field-tough DVC6000 Series digital valve controllers have fully encapsulated printed wiring boards that resist the effects of vibration, temperature, and corrosive atmospheres. A separate weather-tight field wiring terminal box isolates field-wiring connections from other areas of the instrument.

- **Increased Uptime**—With the self-diagnostic capability of DVC6000 Series digital valve controllers, you can answer questions about a valve’s performance, without pulling the valve from the line. You can run diagnostics (I/P and relay integrity, travel deviation, and on-line friction and deadband analysis and trending) while the valve is in service and operating. You can also compare the present valve/actuator signature (bench set, seat load, friction, etc.) against previously stored signatures to discover performance changes, before they cause process control problems.

- **Faster Commissioning**—The two-way communication capability allows you to quickly commission loops by remotely identifying each instrument, verifying its calibration, reviewing stored maintenance notes, and more.

- **Easy Maintenance**—DVC6000 Series digital valve controllers are modular in design. The single master module can be removed from the instrument housing without disconnecting the field wiring, pneumatic connections or stem linkages. This module contains the critical sub-modules so component removal is quick and simple.

Diagnostics

DVC6000 Series digital valve controllers are packed with user-configurable alerts and alarms. When integrated with a HART communication-based system, these flags provide real-time notification of current and potential valve and instrument problems. With AMS ValveLink® Software, tests can be performed to identify problems with the entire control valve assembly. Diagnostic capabilities available are Performance Diagnostics (PD) and Advanced Diagnostics (AD).

Performance Diagnostics

Performance Diagnostics enables the use of diagnostics while the valve is in service and operating.

- Red/Yellow/Green Condition Indicator (see figure 3)
- I/P and Relay Integrity Diagnostic
- Travel Deviation Diagnostic
- 1-Button Diagnostic
- On-Line Friction and Deadband Analysis (see figure 4)
- Friction and Deadband Trending

While all diagnostics can be run while the valve is inline, only the Performance Diagnostics can be performed while the valve is in service and operating.

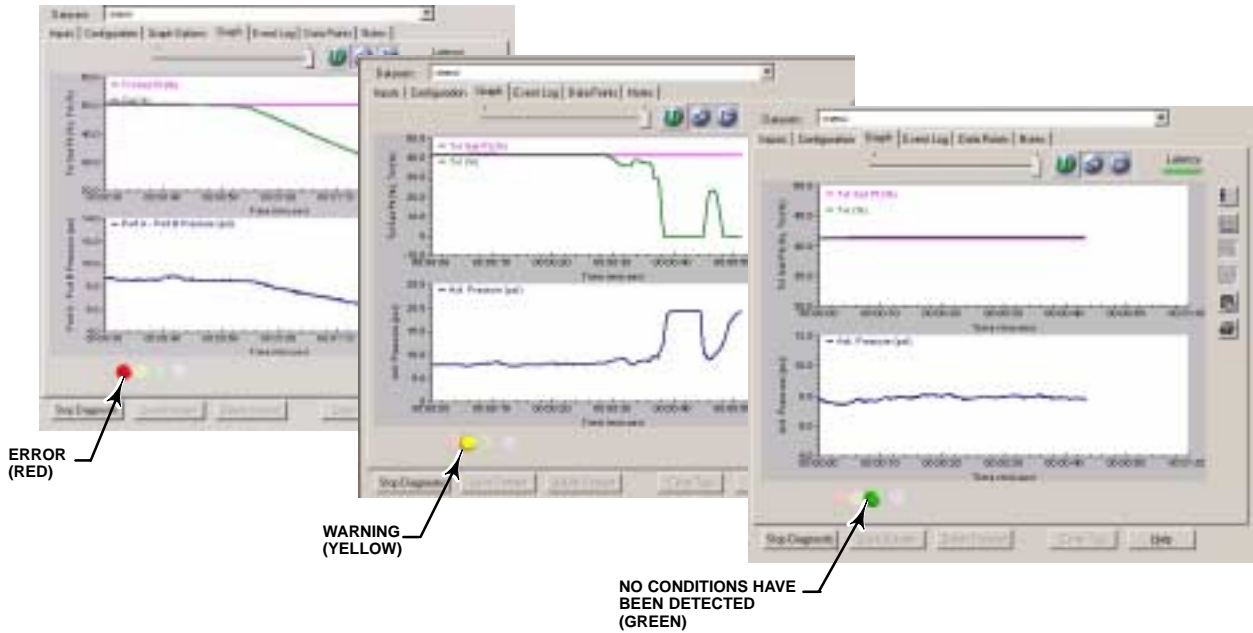

Figure 3. Red/Yellow/Green Condition Indicators, Shown in AMS ValveLink Software

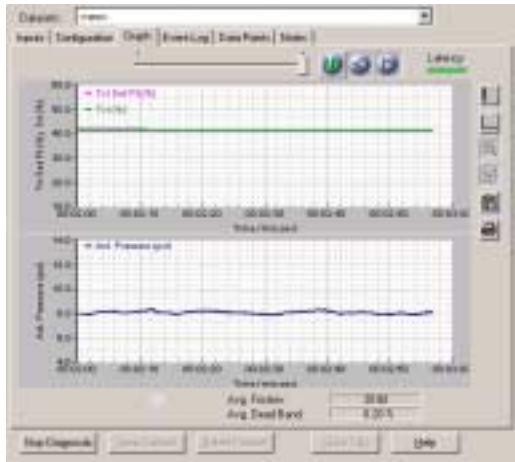

Figure 4. Valve Friction and Deadband Analysis

Advanced Diagnostics

Advanced Diagnostics include the following dynamic scan tests:

- Valve Signature (see figure 6)
- Dynamic Error Band
- Instrument Drive Signal

These diagnostic scans vary the positioner set point at a controlled rate and plot valve operation to determine valve dynamic performance. The valve signature test allows you to determine the valve/actuator friction, bench set, spring rate, and seat load. The Dynamic Error Band test is a combination of hysteresis and deadband plus “slewing.” Hysteresis and deadband are static measurements. However, because the valve is moving, a dynamic error, or “slewing” error is introduced.

Dynamic scan tests give a better indication of how the valve will operate under process conditions which are dynamic, not static.

The Step Response Test checks the valve assemblies response to a changing input signal. and plots travel versus time. The end results of this test allow you to evaluate the dynamic performance of the valve. The Performance Step Test (25 pre-configured points) provides a standardized step test with which to evaluate your valve performance. It utilizes small, medium and large changes.

Advanced Diagnostics are performed with AMS ValveLink Software . The valve must be out of service for Advanced Diagnostics to be performed.

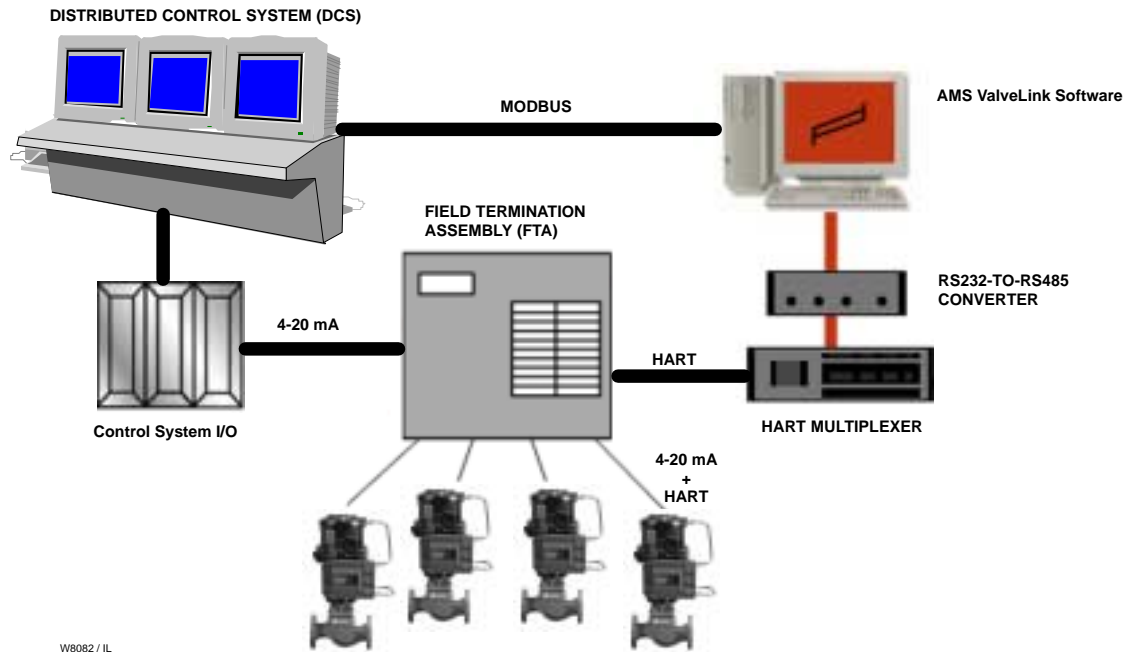

W8082 / IL

Figure 5. Integrate Information from the Digital Valve Controller into a Non-HART Compatible Control System With AMS ValveLink Software's Modbus Interface

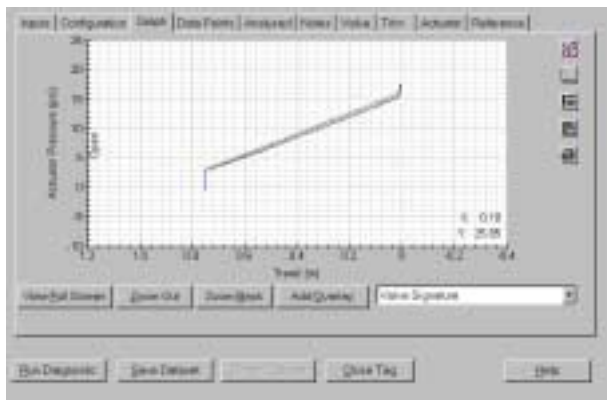

W7468/IL

Figure 6. The Valve Signature Display

Integration

- Non-HART Systems**—Because DVC6000 Series digital valve controllers operate with a traditional 4 to 20 mA control signal, they directly replace older analog instruments. Microprocessor-based electronics provide improved performance along with repeatable and reliable configuration and calibration.

- Modbus with AMS ValveLink Software and HART Multiplexers**—HART communication allows you to extract more value from DVC6000 Series digital valve controllers beyond their inherent improved performance. When integrated into a multiplexer network and using AMS ValveLink Software, the device and valve information is real-time. From the safety of a control room, multiple instruments can be monitored for alerts and alarms. Additionally, tasks such as configuration, calibration and diagnostic testing do not require special trips to the field. AMS ValveLink Software can communicate via Modbus to the distributed control system (DCS) to provide critical information such as valve travel alerts and alarms (figure 5).

- Integrated Control System**—A control system with HART communication capabilities has the ability to directly gather information from DVC6000 Series digital valve controllers. Information such as valve travel, alerts and alarms can be seamlessly accessed to provide a view into the field device from the safety of the control room.

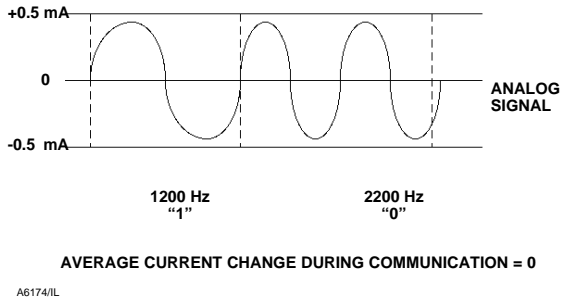

Figure 7. HART® Frequency Shift Keying Technique



Figure 8. Perform Configuration and Calibration at the Valve or Anywhere on the 4 to 20 mA Loop with the Model 375 Field Communicator

Communication

HART Protocol Overview

The HART (Highway Addressable Remote Transducer) protocol gives field devices the capability of communicating instrument and process data digitally. This digital communication occurs over the same two-wire loop that provides the 4 to 20 mA process control signal, without disrupting the process signal (figure 7). In this way, the analog process signal, with its faster response, can be used for control. At the same time, the HART digital communication gives access to calibration, configuration, diagnostic, maintenance, and additional process data. The protocol provides total system integration via a host device.

The HART protocol gives you the capability of multidropping, where you can network several devices to a single communications line. This process is well suited for remote applications such as pipelines, custody transfer sites, and tank farms.

Model 375 Field Communicator

You can perform configuration and calibration at the valve or anywhere on the two-wire loop via a Model 375 Field Communicator (figure 8). Powerful tools such as the Setup Wizard and Auto Travel Calibration automate the tasks of commissioning DVC6000 Series digital valve controllers. These automation tools not only save time, but also provide accurate and repeatable results.

AMS ValveLink Software

AMS ValveLink Software is a Windows-based software package that allows easy access to the information available from DVC6000 Series digital valve controllers.

Using AMS ValveLink Software, you can monitor the performance characteristics of the valve and obtain vital information without having to pull the valve from the line. I/P and Relay Integrity and Travel Deviation Diagnostics, as well as On-Line Friction and Deadband Analysis and Trending can be run while the valve is in service and operating. Valve Signature, Dynamic Error Band, and Step Response are displayed in an intuitive user-friendly environment that allows easy interpretation of data. Diagnostic graphs can be superimposed over those previously stored to view areas of valve degradation. This allows plant personnel to concentrate efforts on equipment that needs repair, avoiding unnecessary maintenance. This diagnostic capability is readily accessible and available to you either in the control room or on the plant floor. In addition to the diagnostic features, AMS ValveLink Software contains an Audit Trail, Batch Runner for automating repetitive tasks, and Trending to view valve performance.

AMS ValveLink Software provides integration into AMS and DeltaV, with HART and Fieldbus communications.

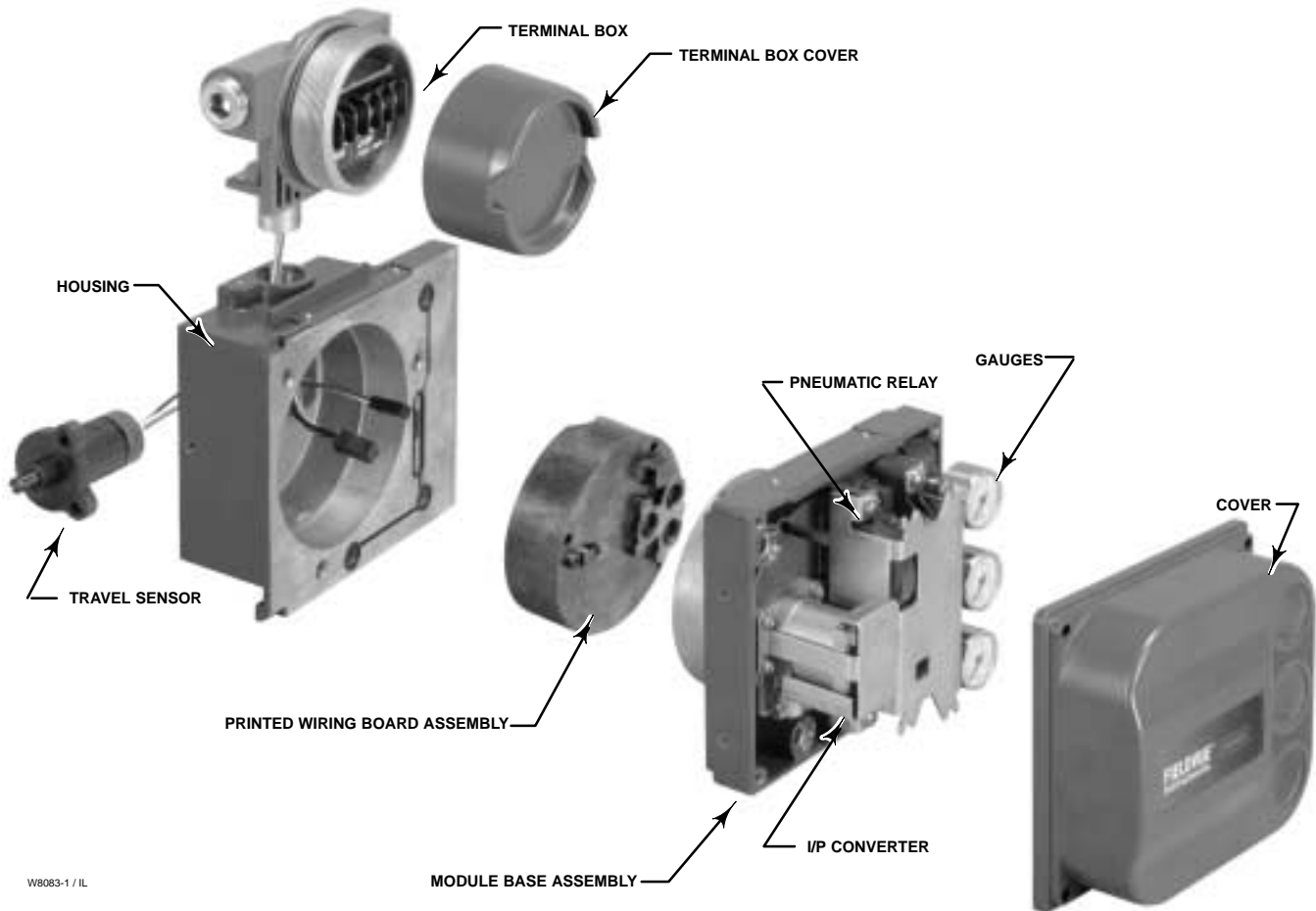

Figure 9. DVC6000 Series Digital Valve Controller Assembly (valve-mounted instrument)

Principle of Operation

DVC6000 Series instruments (figures 9 and 10) receive a set point and position the valve where it needs to be.

- The input signal provides electrical power and the set point simultaneously. It is routed into the terminal box through a twisted pair of wires.
- The input signal is then directed to the printed wiring board assembly where the microprocessor runs a digital control algorithm resulting in a drive signal to the I/P converter.
- The I/P converter assembly is connected to supply pressure and converts the drive signal into a pressure output signal.

- The I/P output is sent to the pneumatic relay assembly. The relay is also connected to supply pressure and amplifies the small pneumatic signal from the I/P converter into a single larger pneumatic output signal used by a single-acting actuator. For double-acting actuators, the relay accepts the pneumatic signal from the I/P converter and provides two pneumatic output signals.

- The change in relay output pressure to the actuator causes the valve to move.

- Valve position is sensed through the feedback linkage by the instrument's travel sensor. The travel sensor is electrically connected to the printed wiring board to provide a travel feedback signal used in the control algorithm.

The valve continues to move until the correct position is attained.

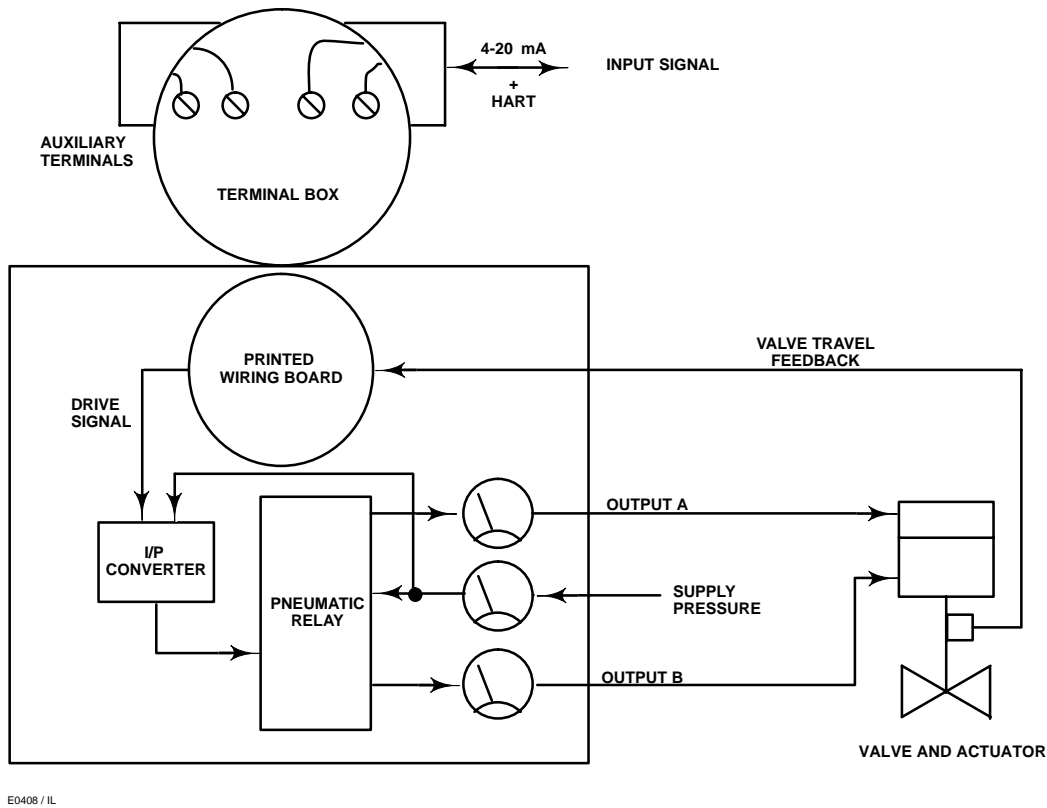

Figure 10. DVC6000 Series Digital Valve Controller Block Diagram

Installation

The Type DVC6010 digital valve controller is designed for yoke mounting to sliding stem actuators. Type DVC6020 digital valve controllers are designed for mounting to rotary actuators or long stroke sliding stem actuators (over 4-inches travel). Type DVC6030 digital valve controllers are designed for mounting on virtually any quarter-turn actuator. Dimensions for valve-mounted instruments are shown in figures 11, 12, and 13. Dimensions for

remote-mounted instruments are shown in figures 14 and 15.

The Type DVC6005 digital valve controller base unit may be remote mounted on 2-inch pipestand or wall. The remote-mounted Type DVC6005 base unit connects to the Type DVC6015, DVC6025, or DVC6035 feedback unit mounted on the actuator. Feedback wiring and pneumatic tubing to the control valve assembly must be connected in the field.

DVC6000 Digital Valve Controller

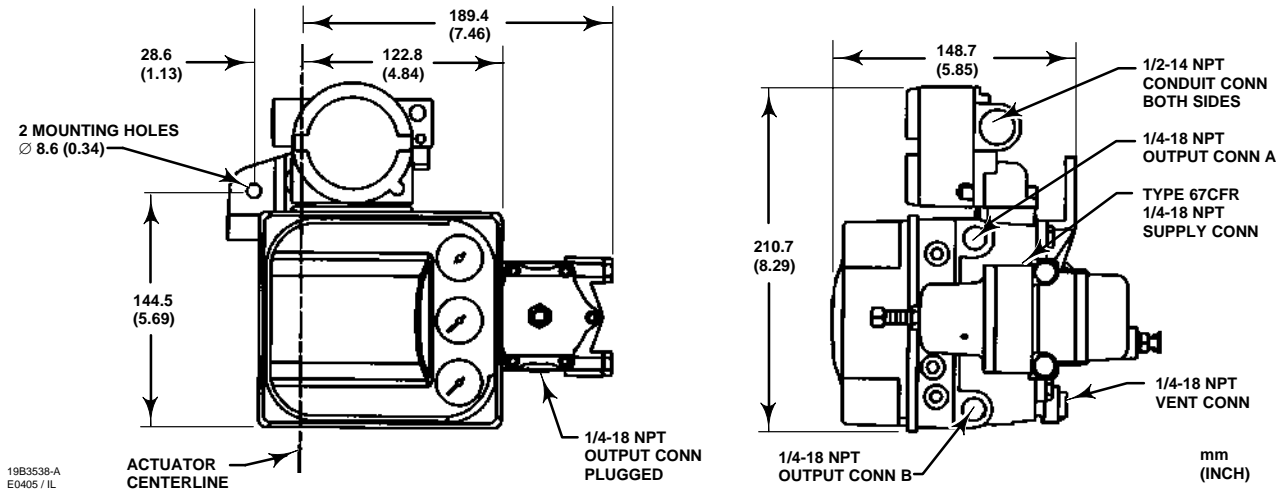

Figure 11. Dimensions for Type DVC6010 Digital Valve Controller with Integrally Mounted Filter Regulator

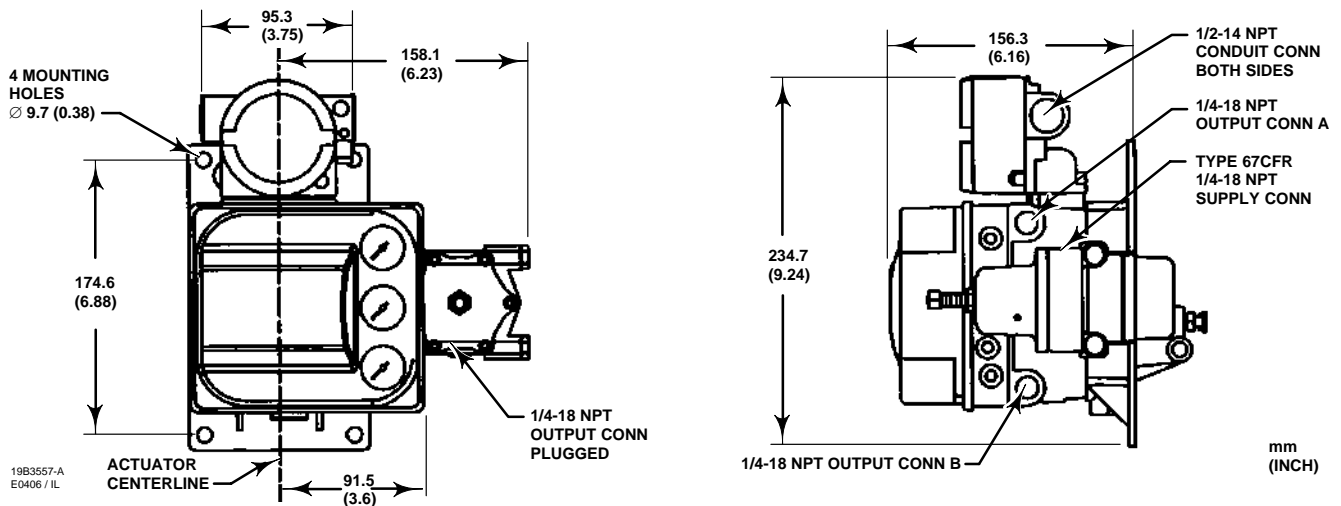

Figure 12. Dimensions for Type DVC6020 Digital Valve Controller with Integrally Mounted Filter Regulator

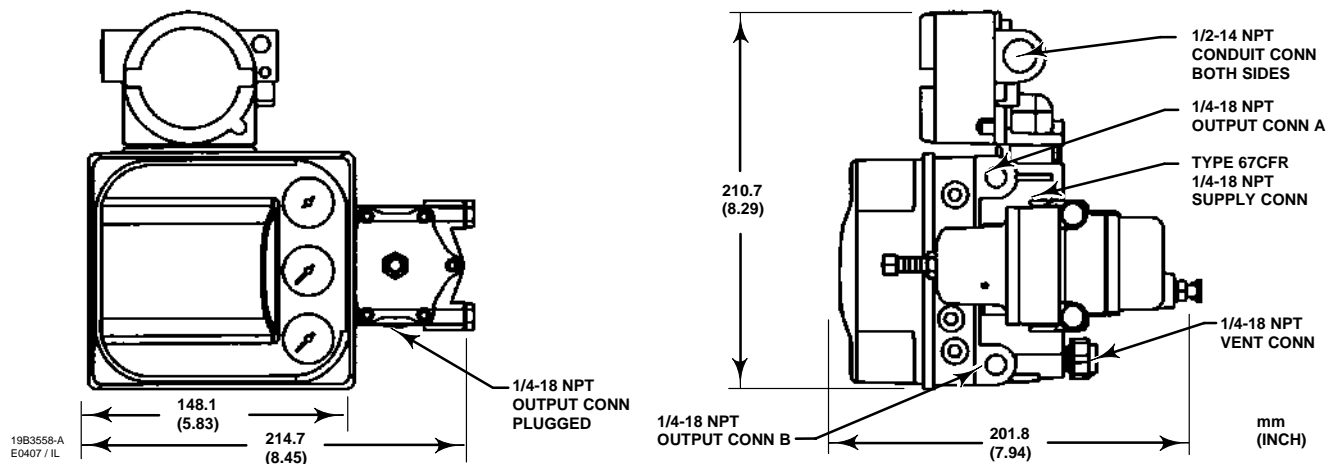

Figure 13. Dimensions for Type DVC6030 Digital Valve Controller with Integrally Mounted Filter Regulator

Product Bulletin

62.1:DVC6000
September 2003

DVC6000 Digital Valve Controller

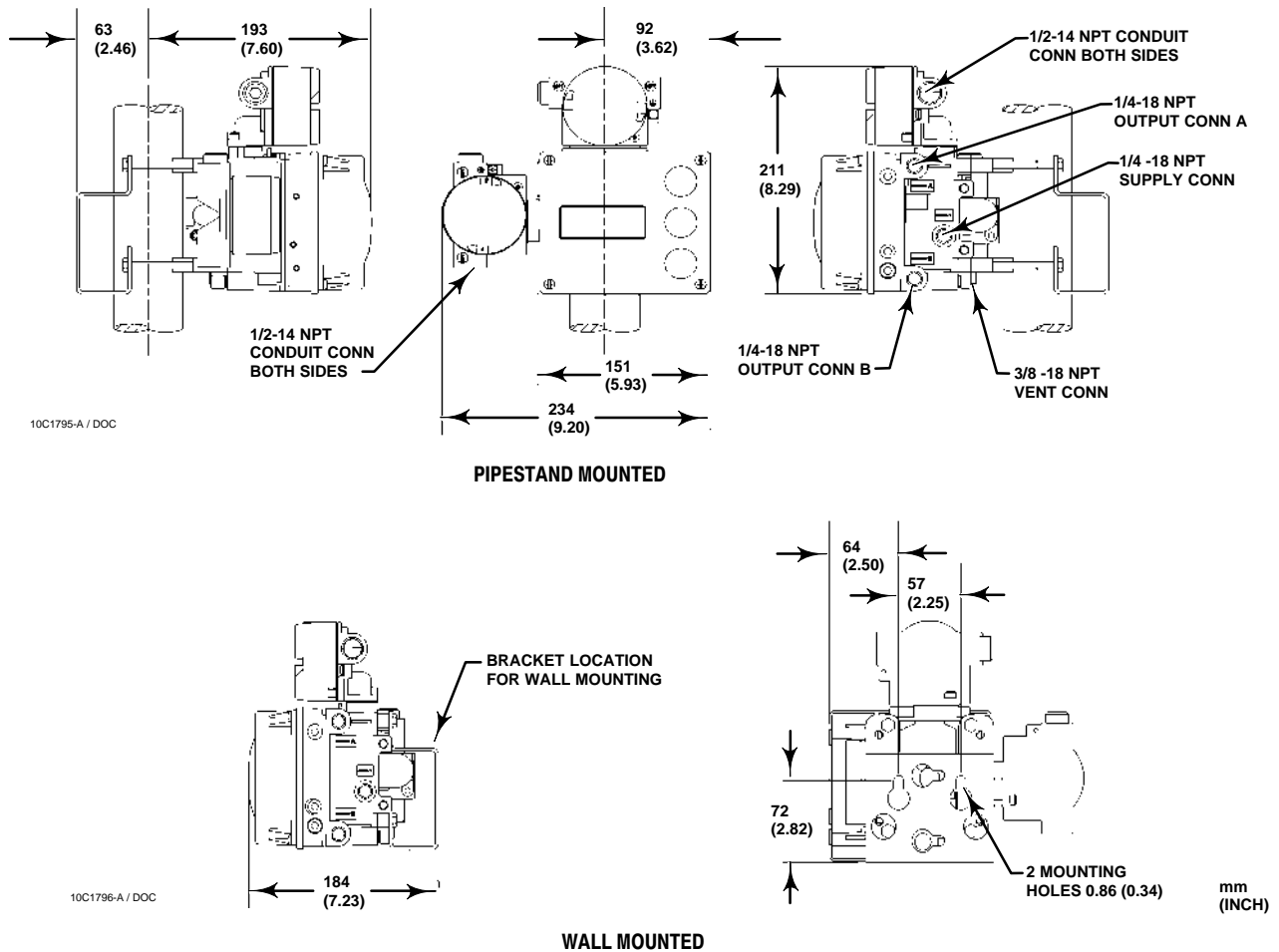

Figure 14. Dimensions for Remote-Mounted Instruments--Type DVC6005 Base Unit

The digital valve controllers are 4 to 20 mA loop powered and do not require additional power. Electrical connections are made in the terminal box.

All pressure connections on the digital valve controllers are 1/4-inch NPT female connections. The digital valve controller outputs are typically connected to the actuator inputs using 3/8-inch diameter tubing. Remote venting is available.

Ordering Information

Note: Fisher does not assume responsibility for the selection, use, or maintenance of any product. Responsibility for proper selection, use, and maintenance of any Fisher product remains solely with the purchaser and end user.

When ordering, specify:

1. Actuator type and size
2. Maximum actuator travel or rotation
3. Options
 - a. Supply pressure regulator
 - b. Supply and output gauges
 - c. HART filter
 - d. Stainless steel housing (valve-mounted instruments only)
 - e. Remote mounting

DVC6000 Digital Valve Controller

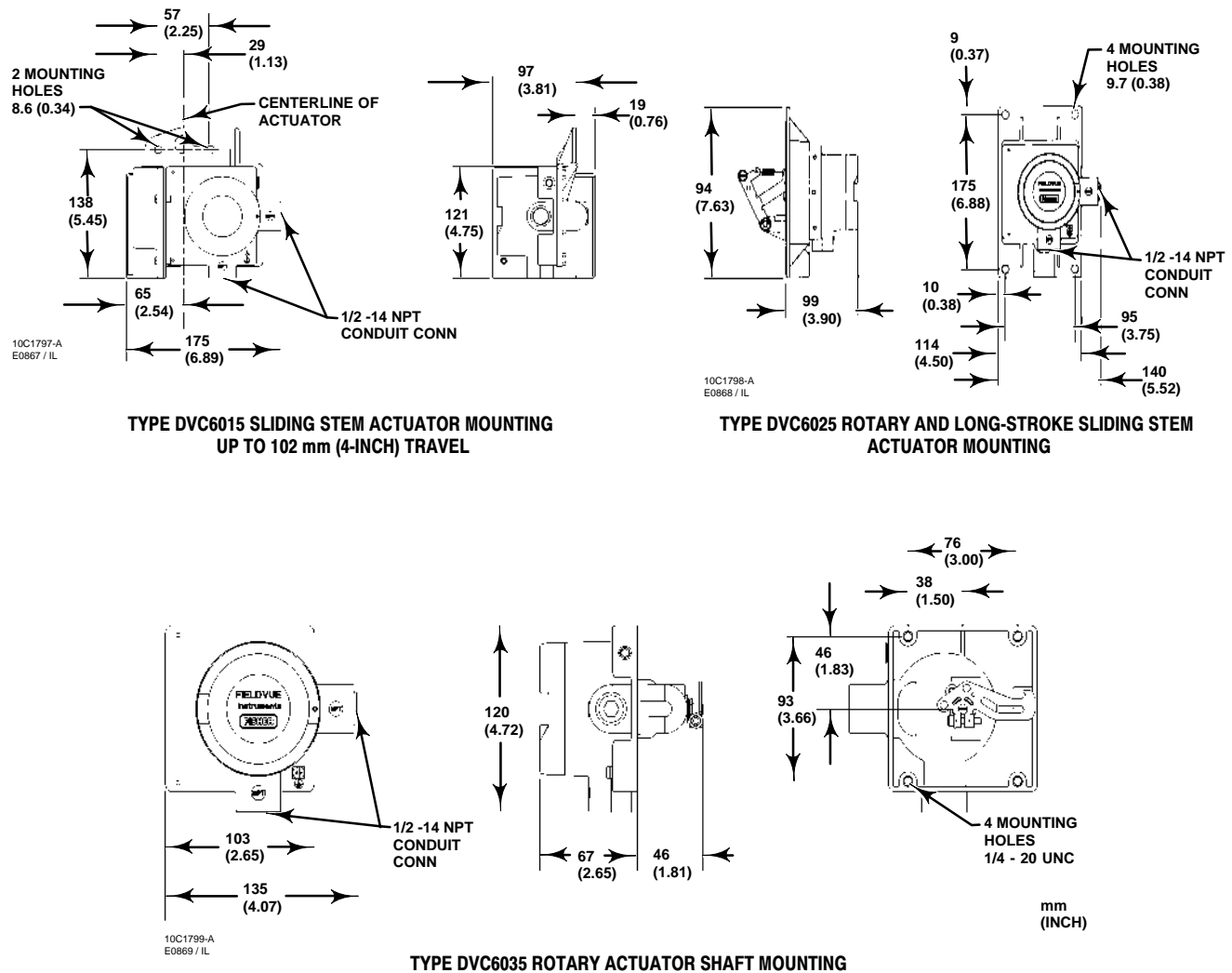

Figure 15. Dimensions for Remote-Mounted Instruments--Feedback Units



FIELDVUE, ValveLink and Fisher are marks owned by Fisher Controls International LLC, a business of Emerson Process Management. The Emerson logo is a trademark and service mark of Emerson Electric Co. HART is a mark owned by the HART Communications Foundation. All other marks are the property of their respective owners. This product may be covered under one or more of the following patents (5,451,923; 5,434,774; 5,439,021; 5,265,637) or under pending patent applications.

The contents of this publication are presented for informational purposes only, and while every effort has been made to ensure their accuracy, they are not to be construed as warranties or guarantees, express or implied, regarding the products or services described herein or their use or applicability. We reserve the right to modify or improve the designs or specifications of such products at any time without notice.

Fisher does not assume responsibility for the selection, use or maintenance of any product. Responsibility for proper selection, use and maintenance of any Fisher product remains solely with the purchaser and end-user.

Emerson Process Management

Fisher

Marshalltown, Iowa 50158 USA
 Cernay 68700 France
 Sao Paulo 05424 Brazil
 Singapore 128461

www.Fisher.com

