

HABONIM
INDUSTRIAL VALVES LTD.

CRYOGENIC VALVE SERIES

3-piece & flanged ball valve



CE

Size Range:	1/4" - 2 1/2" (DN6 - DN65)
Application:	Speciality Gas, Food Processing, Metallurgy, Rubber & Plastic, Transportation, Automotive, Chemical, Dry Cleaning, Electronic & Space
Cryogens:	Nitrogen, Oxygen, Hydrogen, Helium, Argon, Fluorine, Methane
Pressure Range:	Vacuum to 70 bar (1015 psig)
Temperature Range:	-269°C to 100°C (-452°F to 212°F)
Materials:	Stainless Steel, Brass, Monel
End Connections:	Screwed, Socket & Butt weld, Flanged, Extended Ends
Operation:	Hand Operated, Pneumatic or Electric Actuated

HABONIM's line of cryogenic ball valves in 3-piece design or flange design to ANSI class 150# and 300# offer tight shutoff, high flow capacity, long service life with exceptional performance under the most extreme cold working temperature conditions.

Habonim Cryogenic Valves

Habonim Cryogenic ball valves are available in 3-piece or flanged design, reduce bore C47P/C31P/C32P series and full bore CB47P, C73P/C74P/C78P series. Other valve options include diverter valves, V-Port control valves, high cycling valves, fugitive emission valves, automated valves and more.

Valve Features

The Habonim Cryogenic ball valves are designed specifically for cryogenic applications. All the cryogenic valves have an extended bonnet with an ISO 5211 mounting pad. The extension prevents cryogenic liquids from reaching the stem packing by enabling the liquids to boil and convert to gas. The balls have a pressure relief hole on the upstream side to prevent overpressure of the body cavity from thermal expansion. The valve is uni-directional with an arrow showing flow direction.

Other included features are:

- ▶ Straight through-flow providing minimum pressure loss and maximum flow
- ▶ Tight shutoff according to Cryogenic standards
- ▶ Quick opening for automation
- ▶ Rugged construction with precision welding of bonnet extension
- ▶ Blowout proof one-piece stem with enlarged diameter and wide stem-to-ball engagement
- ▶ Seats with specially designed profiles to allow flexible movement under very low temperatures
- ▶ Encapsulated body seals
- ▶ Spring loaded body bolts to compensate for thermal contractions of valve parts during operation
- ▶ Spring loaded stem assembly
- ▶ "V" shape PTFE stem packing with 5 seals to reduce stem leakage
- ▶ Cryogenic valves have a white sleeved handle

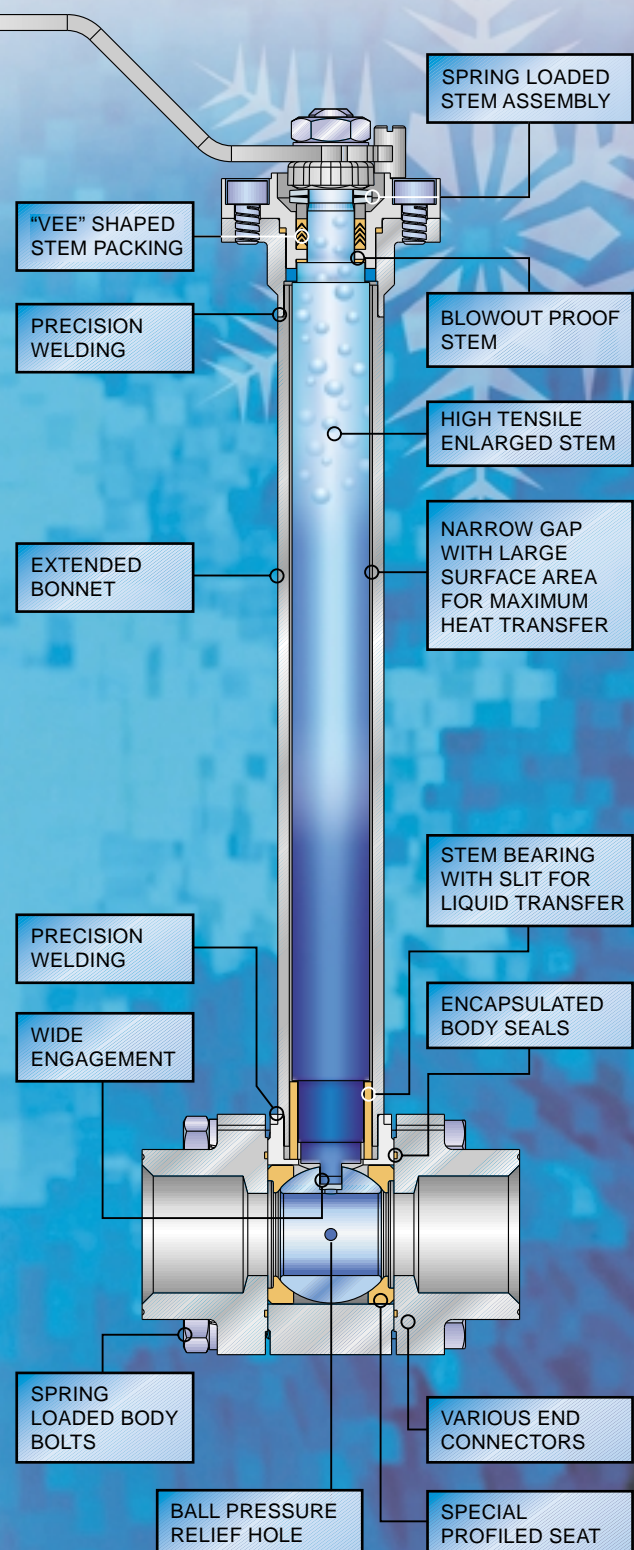



Materials

The valve body and end materials are stainless steel or brass (both are standard) or monel for special applications. The extension bonnet is stainless steel for stainless steel and brass valves and monel for monel valves. The valve balls are stainless steel or monel. The stem is 17-4PH high tensile stainless steel.

The seats are from PCTFE or NRG (Carbon filled PTFE) for limited temperatures to -196°C (-321°F).

The body seals and stem seals are PTFE or Graphite.

End Connections

Stainless steel valves are available with screwed or welding type end connections. Brass valves are available with screwed or soldering type end connections. Optional extended ends for welding or soldering are available on request to avoid valve disassembly during installations.

Cleaning, Assembly, Testing & Packing

Before assembly the valve parts are cleaned in an ultrasonic bath and degreased to ensure a high level of cleanliness and minimum moisture content. All the cryogenic valves are assembled in a clean room and 100% tested with dry nitrogen or with a helium leak detector for leakage. After testing, the ends are capped and the valves are individually packed in a hermetically sealed polyethylene bag filled with dry nitrogen.

Quality Control

As an ISO 9001 certified manufacturer, Habonim is committed to the highest degree of perfection. Habonim cryogenic valves procedures are done according to special requirements to ensure control of tight machining tolerance high surface finish and meticulous materials selection. The quality control department is responsible to ensure that all the specifications throughout the process, including material acquisition, machining, welding, cleaning, assembly, pressure testing, packaging and final inspection are kept to the highest degree. Certification and test data are available for the customers.

VALVE SIZE	Cv Values FLOW COEFFICIENTS				Limiting Stem Input Torque*	
	47P Series		31P Series		17- 4PH Stem material	
inch	Cv	Kv	Cv	Kv	Nm	in-lb
1/2"	8	6.9	7	6	91	805
3/4"	12	10.4	10.0	9	91	805
1"	32	28.1	30.0	26.0	165	1,460
1 1/4"	57	49.3	NA	NA	165	1,460
1 1/2"	80	69.2	90.0	78.0	268	2,372
2"	104	90.0	130	112	268	2,372
2 1/2"	240	208	NA	NA	268	2,372

Cv - Flow in US GPM at 1 psi pressure drop.

Kv - Flow in m³/hr at 1 bar pressure drop.

Valve flow rates are determined in full open position with water at 15 C° (60 F°).

* Limiting Stem torque figures are based on random laboratory tests.

These are not to be confused with valve torque.

Pressure / Temperature Rating

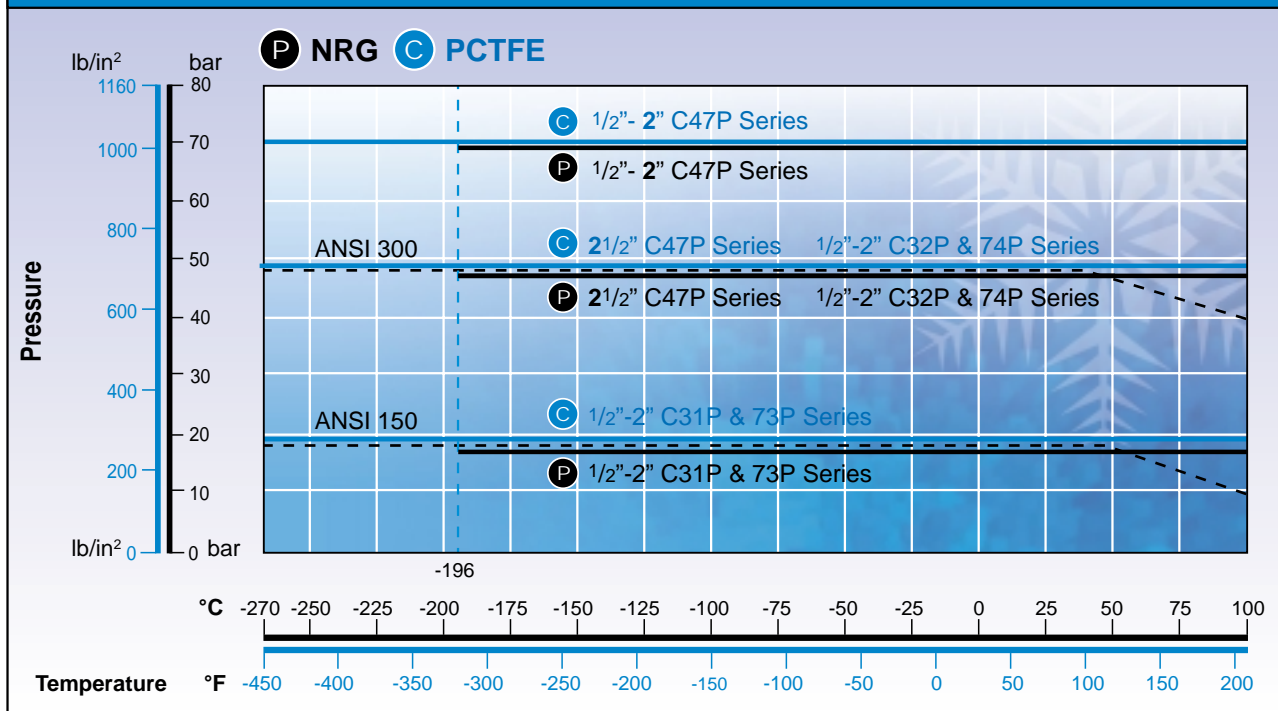

Material Specifications

ITEM	DESCRIPTION	MATERIAL	QTY.
1	BODY	S.ST. ASTM A351 CF8M	1
2	BODY CONNECTOR	S.ST. ASTM A351 CF3M	1
3	BALL (WITH RELIEF HOLE)	S.ST. 316 ASTM A276	1
4	STEM	S.ST. 17-4PH	1
5	SEAT RING	PCTFE, NRG	2
6	BODY SEAL	PTFE	1
7	THRUST SEAL	PTFE CARBON FILLED	1
8	BOTTOM GLAND PACKING	PTFE	1
8a	MIDDLE GLAND PACKING	PTFE	3
8b	TOP GLAND PACKING	PTFE	1
9	GLAND	S.ST. 316L ASTM B783	1
10	DISC SPRING GLAND NUT	S.ST. 17-7PH	2
11	GLAND NUT	S.ST. 316 ASTM A194	1
12	LOCKING CLIP	S.ST. 304 ASTM A164	1
13	HANDLE	S.ST. 430 ASTM A240	1
14	SERRATED WASHER	S.ST. 410	1
15	HANDLE NUT	S.ST. 316 ASTM A194	1
16	STOP PIN	S.ST. 303 ASTM A582	1
17	HANDLE SLEEVE WHITE	VINYL PLASTISOL	1
18	TOP FLANGE SEAL	PTFE	1
19	TOP FLANGE	S.ST. 316 ASTM A276	1
20	TOP FLANGE BOLTS	S.ST. A2-70 ISO 4014	4
21	STEM BEARING	PTFE	1
22	BODY CONNECTOR BOLTS	S.ST. A2-70 ISO 4014	4
23	BODY CONNECTOR SPRING	S.ST.	4
24	BODY CONNECTOR NUTS	S.ST. A4-70 ISO 4032	4

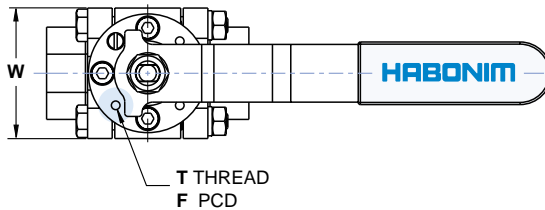
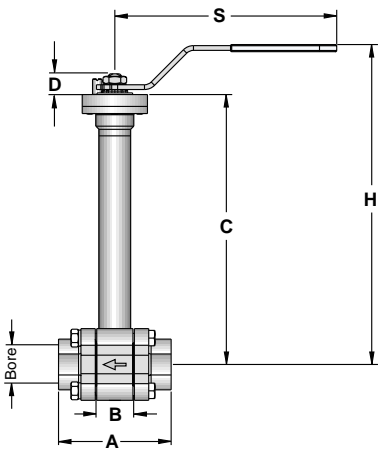
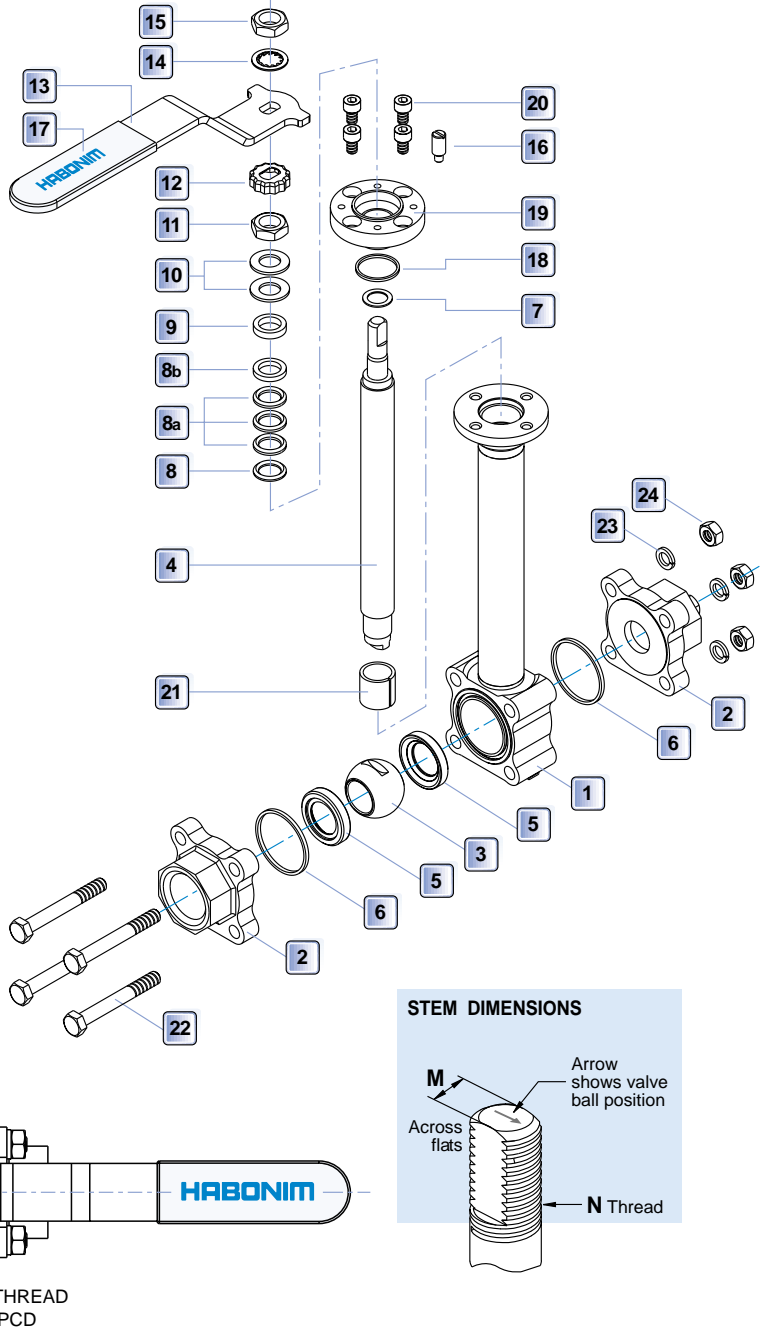

STEM DIMENSIONS

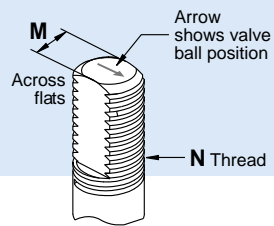

Valve Dimensions 1/2" - 2 1/2"

SIZE	UNIT	BORE	A	B	C	D	H	S	W	M	N	T	F (ISO)
1/2"	mm	11.1	66	20.6	208	9.0	242	150	47.0	5.5	3/8"	M5	36.0 (F03)
	inch	0.44	2.598	0.811	8.189	0.354	9.528	5.906	1.850	0.217	UNF		1.42
3/4"	mm	14.3	71	24.5	210	9.0	244	150	53.7	5.5	3/8"	M5	36.0 (F03)
	inch	0.56	2.795	0.965	8.268	0.354	9.606	5.906	2.114	0.217	UNF		1.42
1"	mm	20.6	95	31.7	227	17.5	273	187	63.7	7.54	7/16"	M5	42.0 (F04)
	inch	0.81	3.740	1.248	8.937	0.689	10.748	7.362	2.507	0.297	UNF		1.65
1 1/4"	mm	25.4	108	40.9	233	17.5	275	187	71.7	7.54	7/16"	M5	42.0 (F04)
	inch	1.00	4.252	1.610	9.173	0.689	10.827	7.362	2.822	0.297	UNF		1.65
1 1/2"	mm	31.8	115.5	48.4	270	29.5	320	237	86.7	8.71	9/16"	M6	50.0 (F05)
	inch	1.25	4.547	1.906	10.630	1.161	12.598	9.331	3.413	0.343	UNF		1.97
2"	mm	38.1	128	56.3	275	29.5	326	237	96.9	8.71	9/16"	M6	50.0 (F05)
	inch	1.50	5.039	2.217	10.827	1.161	12.835	9.331	3.815	0.343	UNF		1.97
2 1/2"	mm	50.8	158	72.6	296.5	41.5	342	237	108	8.71	9/16"	M8	70.0 (F07)
	inch	2.50	6.220	2.858	11.673	1.634	13.465	9.331	4.252	0.343	UNF		2.75



Material Specifications

ITEM	DESCRIPTION	MATERIAL	QTY.
1	BODY	S.ST. ASTM A351 CF8M	1
2	INSERT	S.ST. ASTM A351 CF8M	1
3	BALL (WITH RELIEF HOLE)	S.ST. 316 ASTM A276	1
4	STEM	S.ST. 17-4PH	1
5	SEAT RING	PCTFE, NRG	2
6	BODY SEAL	PTFE	1
6a	BODY SEAL METAL RING	S.ST. 316 ASTM 276	1
7	THRUST SEAL	PTFE CARBON FILLED	1
8	BOTTOM GLAND PACKING	PTFE	1
8a	MIDDLE GLAND PACKING	PTFE	3
8b	TOP GLAND PACKING	PTFE	1
9	GLAND	S.ST. 316L ASTM B783	1
10	DISC SPRING GLAND NUT	S.ST. 17-7PH	2
11	GLAND NUT	S.ST. 316 ASTM A194	1
12	LOCKING CLIP	S.ST. 304 ASTM A164	1
13	HANDLE	S.ST. 430 ASTM A240	1
14	SERRATED WASHER	S.ST. 410	1
15	HANDLE NUT	S.ST. 316 ASTM A194	1
16	STOP PIN	S.ST. 303 ASTM A582	1
17	HANDLE SLEEVE WHITE	VINIL PLASTISOL	1
18	TOP FLANGE SEAL	PTFE	1
19	TOP FLANGE	S.ST. 316 ASTM A276	1
20	TOP FLANGE BOLTS	S.ST. A2-70 ISO 4014	4
21	STEM BEARING	PTFE	1

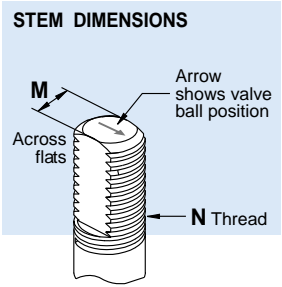
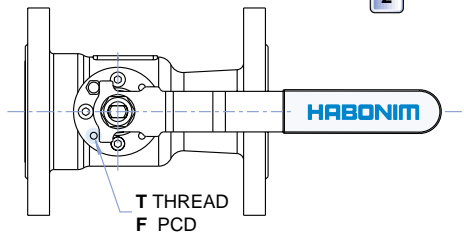
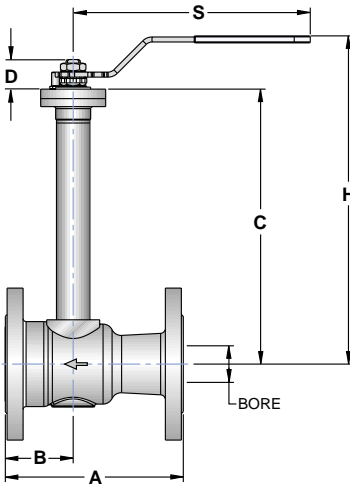
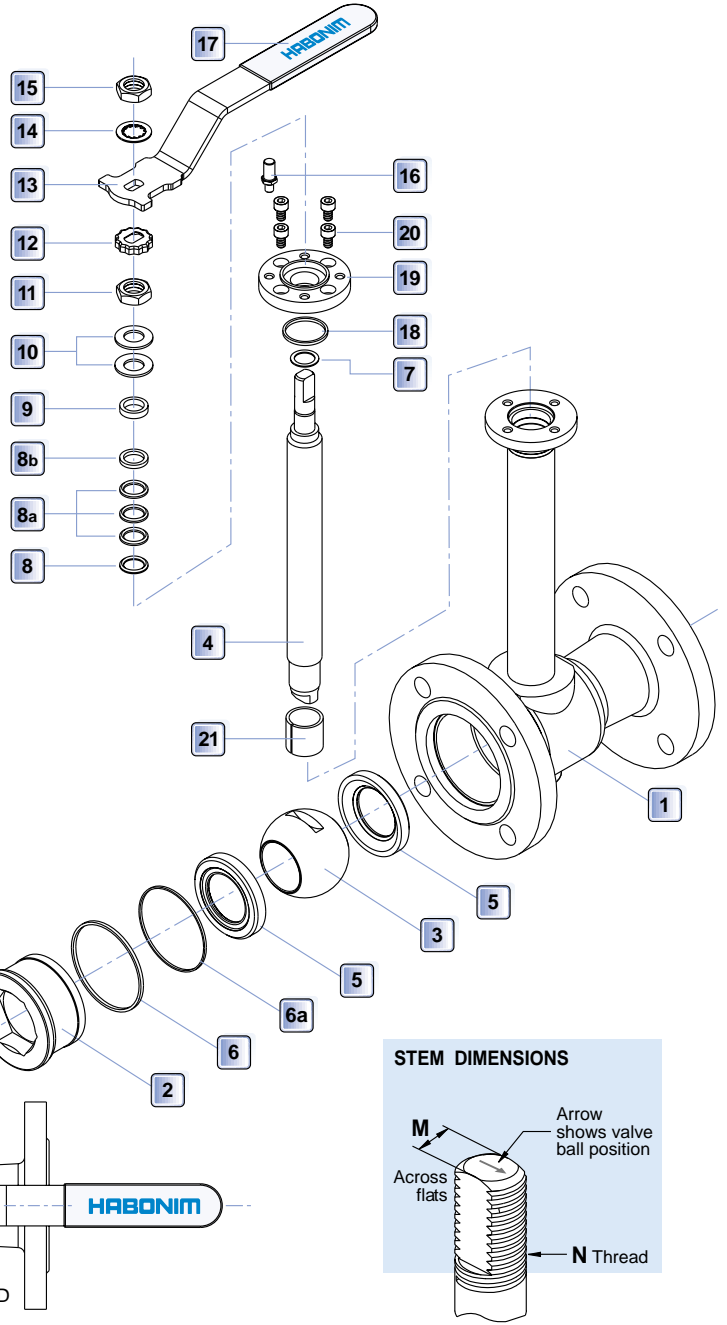

Valve Dimensions 1/2" - 2"

VALVE SIZE	BORE	A		B	C	D	H	S	M	N	T	F (Iso)	
		150	300										
1/2"	mm	11.1	108.0	140	46.0	29.0	38.0	92.0	151.0	5.54	3/8"	M5	36.0 (F03)
	in	0.44	4.25	5.5	1.81	1.14	1.5	3.62	5.94	0.218	UNF		1.42
3/4"	mm	14.3	117.0	152.0	49.3	31.4	40.3	94.0	151.0	5.54	3/8"	M5	36.0 (F03)
	in	0.56	4.61	6.0	1.94	1.24	1.59	3.7	5.94	0.218	UNF		1.42
1"	mm	20.6	127.0	165.0	57.2	38.2	55.6	103.5	170.0	7.54	7/16"	M5	42.0 (F04)
	in	0.81	5.0	6.5	2.25	1.50	2.19	4.07	6.69	0.296	UNF		1.65
1 1/2"	mm	31.8	165.0	190.0	62.3	43.6	73.1	119.2	220.5	8.7	9/16"	M6	50.0 (F05)
	in	1.25	6.5	7.5	2.45	1.72	2.88	4.7	8.68	0.343	UNF		1.97
2"	mm	38.1	178.0	216.0	67.8	48.3	77.8	123.9	220.5	8.7	9/16"	M6	50.0 (F05)
	in	1.50	7.0	8.5	2.67	1.90	3.06	4.88	8.68	0.343	UNF		1.97

Valve Torque

Due to the nature of cryogenic fluids, valve torque can increase as a result of freezing moisture on the ball or thermal contractions of the materials. It is recommended to allow enough safety factor when calculating for actuator sizing. The torque curve of valves at cryogenic temperatures behaves different to those at ambient temperatures as illustrated below.

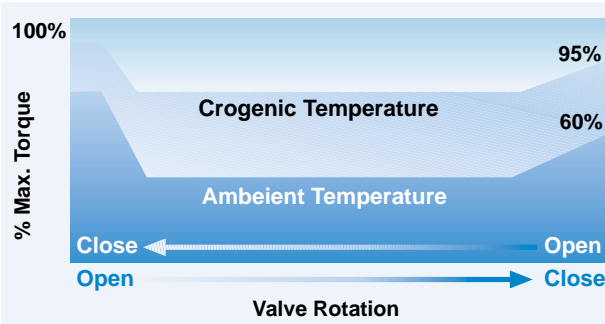

The torques in the table below are based on empirical laboratory testing at cryogenic temperature using PCTFE and NRG seats at pressures up to 10 bar (150 psi). For additional information please consult with Habonim.

Cryogenic Torque Charts using PCTFE seats							
Size	1/2"	3/4"	1"	1 1/4"	1 1/2"	2"	2 1/2"
NM	10	15	30	40	55	70	85
In-lb	88.5	133	265	354	487	620	752
Cryogenic Torque Charts using NRG seats							
Size	1/2"	3/4"	1"	1 1/4"	1 1/2"	2"	2 1/2"
NM	8	12	23	31	40	50	65
In-lb	71	106	203	274	354	443	575

Safety

Cryogenic valves are unidirectional and must be installed in the correct flow direction. In the open position the valve wrench points to the flow direction as illustrated below. The stem has an arrow pointing to the flow direction.

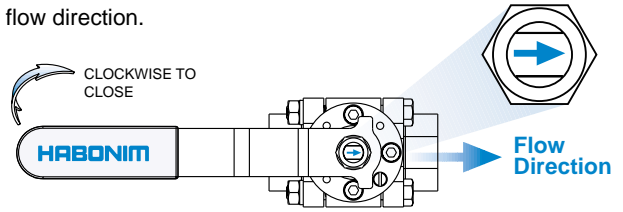

The ball has an upstream pressure relief hole to prevent overpressure from thermal expansion. The valves have an arrow welded to the body showing flow direction.

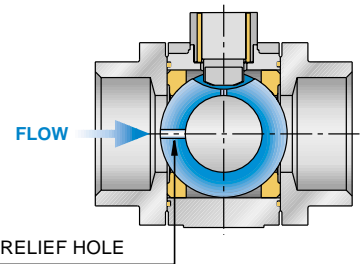

The valves have a blowout proof stem supported by the top flange, enabling stem packing to be maintained while the valve is under pressure. The top flange is bolted to the body bonnet by 4 screws. Any trapped pressure in the bonnet will relief through the seals before the top flange can removed and prevent accidental blowout of the stem.

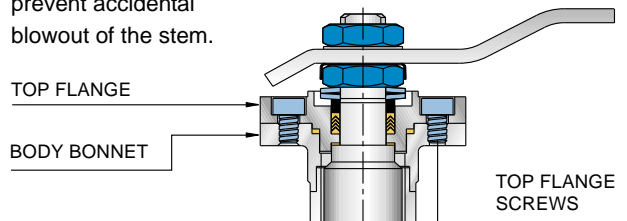

Actuated Valves

Where automation is required, the cryogenic ball valves are available with Habonim's unique 4-Piston pneumatic Compact actuator. The actuators are available in spring return or double acting. Limit switches and positioners can be mounted on the actuator top face according to NAMUR or ISO bolt pattern interface. For more information please refer to Bulletin B-310.

Valve Actuator Sizing

VALVE SIZE	Double Acting (DA)			Spring Return (SR)		
	60 psi	80 psi	100 psi	60 psi	80 psi	100 psi
1/2"	H15	H15	H15	H25-2A2B	H25-2C	H20-3
3/4"	H20	H15	H15	H25-2A2B	H25-2C	H20-3
1"	H25	H20	H20	H35-2A2B	H30-2C	H30-3
1 1/4"	H25	H25	H20	H35-2A2B	H30-2C	H30-3
1 1/2"	H30	H25	H25	H45-2A2B	H35-2C	H35-3
2"	H30	H30	H25	H45-2A2B	H35-2C	H35-3
2 1/2"	H30	H30	H25	H45-2A2B	H45-2C	H35-3

The sizing table is for Habonim Compact actuators mounted on Habonim Cryogenic valves fitted with PCTFE seats.

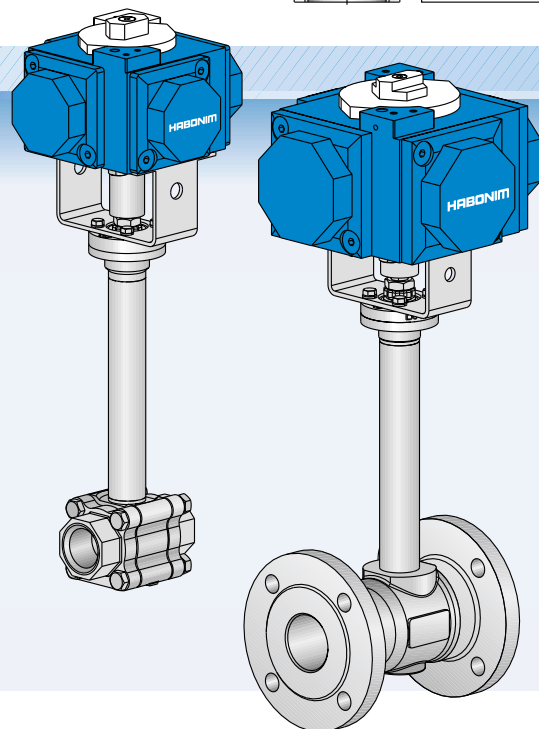



Cryogenic Service Applications

Valves are used with cryogenics from production through transportation and storage which serve many industries with gases such as oxygen, nitrogen, argon and more. At extremely low temperatures of cryogenic liquids, many common materials become brittle and can crack. Many materials also shrink, causing potentially leaks at connections. Therefore, care must be taken when designing equipment and selecting materials to be used with cryogenics. Moisture must not be allowed to contaminate the valve as it will freeze and expand and cause leakage and abrasive damage to the equipment. Some of the common gases used are listed below.

FLUID	Boiling Point		FLUID	Boiling Point	
	°F	°C		°F	°C
Helium	-452.1	-268.9	Argon	-302.6	-185.9
Hydrogen	-423.0	-252.8	Oxygen	-297.3	-182.9
Nitrogen	-320.5	-195.8	Natural Gas	-270.0	-167.8
Air	-318.0	-194.4	Methane	-258.6	-161.4
Fluorine	-306.2	-188.0	Carbon Dioxide	-109.0	-78.3

Absolute Zero = -273.2°C (-460°F)

Cryogenic Valve Testing

In order to maintain valve reliability Habonim has an in-house testing facility for cryogenic valves to ensure the quality of the valves and their functionality. These tests include valve leakage, torques and cycling under typical cryogenic conditions. The tests are carried out in a cryogenic bath or in-line under pressure according to standard requirements of international procedures such as AFNOR and BS.



Diverter Cryogenic Valve

Habonim's line of diverting cryogenic valves are available in bottom entry or side entry. The valves have balls with "T" or "L" port configurations that reduce the number of valves in a system, thereby saving costs and giving the user easier control by using a single valve in place of multiple valves.

V-Port Control Cryogenic Valve

The Habonim line of V-Port control valves are available in cryogenic applications giving the advantage of precise control with tight shutoff. The valves have a characterized metal seat in the downstream side with "V" notch for equal percentage flow or slots for linear flows.

Fugitive Emission Cryogenic Valve

Fugitive emissions regulations require chemical plants to monitor valves for stem leakage. The Habonim cryogenic valve is available with a Fugitive Emission Bonnet design, offering a high integrity solution for toxic gases or high cycle applications.

Wafer Style Cryogenic Valve

Where special materials are requested, such as Monel or others, Habonim wafer style cryogenic valves offer an ideal solution. The valves internal parts such as ball, stem, seats and seals are all interchangeable with the standard cryogenic valves.



Identification Code

The HABONIM Cryogenic Ball Valve Identification Code

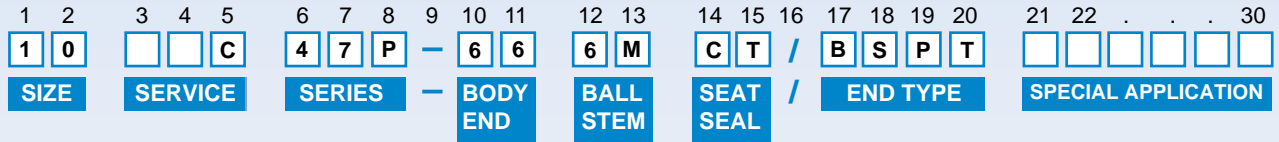

SIZE			SERIES	SERVICE	BODY / END	SEAT	END CONNECTION **
Code	Inch	mm					
02	1/4"	8	47 Standard ISO pad	A Antistatic	1 Bronze	C PCTFE	BSPT BS 21
03	3/8"	10		B Full bore	5 Brass	P NRG	
05	1/2"	15	31 ANSI 150#	*C Cryogenic	6 S. St. 316 (L)	M Metal	DIN DIN 2999 (BSPP)
07	3/4"	20	32 ANSI 300#	D Diverter	7 Monel	SEAL	NPT B1.20.1
10	1"	25	73 ANSI 150# Full Bore	F Firesafe	8 S. St. 304		I Graphite Impregnated
12	1 1/4"	32	74 ANSI 300# Full Bore	L Let Lok	BALL / STEM		
15	1 1/2"	40	78 DIN PN40 Full Bore	N Control	6 S. St. 316	G Graphite Reinforced	SW Socketweld
20	2"	50		O Oxygen	S Diverter side entry	M S. St. 17-4PH	M S. St O-Ring PTFE coated
25	2 1/2"	65	V Vacuum		7 Monel	T PTFE	BWO OD tube
					8 S. St. 304		ETO Extended OD tube
							SWO Socketweld OD tube
							KLM Copper tube
							ETB Extended Copper tube
							LL Let Lok (Inch)
							LM Let Lok (Metric)
							PN40 Flanged DIN PN40/F1

* When using the prefix "C" the valve will always have a ball with pressure relief hole on the upstream side.
 ** Other end connections are available on request.

Special Application

- 90° Diverter ball valve 90° turn **FE** Fugitive Emission
- 180° Diverter ball valve 180° turn **V60** Control valve seat
- P250** Ball with upstream pressure relief hole **K** LLP Locking device
- EP** Electro Polish



How to order

Habonim cryogenic valves are identified by the prefix "C". When placing an order for HABONIM cryogenic valves, it is essential to provide as many details possible on the application such as: media, temperature, pressure, pipe line size and type of connection. Refer to the Habonim Code System for further details.

Example: 10 C47P - 666MCT / BW

Size 1" (10), Cryogenic (C), 3-piece (47P), S. St Body (6) S. St Ends (6), S. St Ball (6), 17-4PH Stem (M), PCTFE Seats (C), PTFE Body Seals (T), Buttweld ends (BW).

In accordance with our policy to strive for continuous improvement of the product, we reserve the right to alter the dimensions, technical data and information included in this catalogue when required.