

31P/32P Series ANSI Class 150 & 300



Flanged Standard Bore Ball Valve

Size Range:	1/2" - 8" (DN15 - DN200)
Flange Connection:	31P Series - ANSI class 150 32P Series - ANSI class 300
Application:	Chemical, Petrochemical, Oil and Gas production, Refining, Energy, Pulp & Paper and others
Service:	Steam, Chemicals, LP-Gas, Thermal Fluid, Chlorine, Ammonia, Sour Gas
Materials:	Carbon Steel, Stainless Steel, Hasteloy-C, Alloy-20, Monel, Duplex
Certifications:	Firesafe to API 607 4 th Edt., BS 6755 Pt 2, API 6FA Lloyds Type Approved to BS 5351, ISO 9001, PED 97/23/EC
Operation:	Hand or Gear operated, Pneumatic or Electric Actuated

The **31P/32P** Series are **HABONIM**'s line of one piece fully flanged reduced bore ball valves in ANSI class 150# and ANSI class 300#. **HABONIM**'s flanged valves offer tight shutoff, long service life and high durability with exceptional performance in many service applications under the most severe working conditions.

Construction

All valve are one piece design. The valve bodies have a top mounting flange conforming to ISO 5211 for direct mounting of actuators, limit switches, fugitive emission bonnets or extended handles.

Seats

Flexible seat design provides tight shutoff at high and low pressures, reduce wear and valve torque. A wide range of seat materials are available. Standard seat materials are Virgin PTFE, glass filled PTFE or carbon filled PTFE. For other seat materials, please refer to Bulletin T-624 or consult with Habonim.

Stem

The valve stem assemblies have blowout proof stems with live loaded spring washers to compensate for pressure and temperature surges and wear.

Ball

A highly polished solid ball with a pressure relief hole in the stem slot to equalise the pressure in the body cavity ensures tight shutoff and long service life.

Body and Trim Materials

The standard valve body materials are 316 Stainless Steel and Carbon Steel grades WCB and LCB. Standard trim material for ball and stem is 316 Stainless Steel. Trim materials such as Monel, Hastelloy-C, Alloy-20, Duplex and others are available for specific applications.

Antistatic

The valve stem has a built in antistatic device which ensures continuous contact of stem-to-ball and stem-to-body.

Valve Finish

Carbon Steel valves are phosphate and oil dipped. Stainless Steel valves are natural.

Interchangeability

Valve ball, stem, seats and seals are interchangeable with the Habonim **46/47 Series** three piece ball valve.

Fire Safe Valves

Fire Safe valves are designed and tested to the requirements of API 607 4th Edition and to BS 6755 Part 2 specifications. Valves for fire safe application are identified by the prefix "**AF**". Fire Safe certificates for valves, if necessary should be requested .

Secondary sealing

All fire safe valves are fitted with flexible graphite body seals and graphite stem seals.

The valves contain soft seat rings. In the event of fire, a secondary metallic machined ring comes in contact with the ball and prevents leakage through the valve port. The stem incorporates a machined ring shaped surface which will prevent leakage, once the thrust seal has been burned off.

Special Service

Valves prepared for special services such as Dry Chlorine, Oxygen, Hydrogen Peroxide, Ammonia, Vacuum, Steam, Thermal fluids and low temperature service are in accordance with the relevant standards.

Other designs available include Control valves with V-Ported seats, Diverter valves, Steam Jacketed valves, Cryogenic valves and Double-Block & Bleed valves. Valves are approved to UL-125 for Liquid Petroleum Gas. Sour gas service valves are to NACE MR-01-75. Ask for the relevant bulletins for all these applications.

Other available accessories

- **Stem extensions** for valves.
- **Fugitive Emission** kits for hazardous fluids.
- **Locking devices** for securing valve position.
- **Manual gear Operators** for operating large valves.
- **Dec clutchable gear operators** for actuated valves.
- **Spring return handle** (Dead man lever) using the Habonim Compact spring return actuator fitted with a handle extension.
- **Limit switches** for on-off indication.

Pressure / Temperature Graph

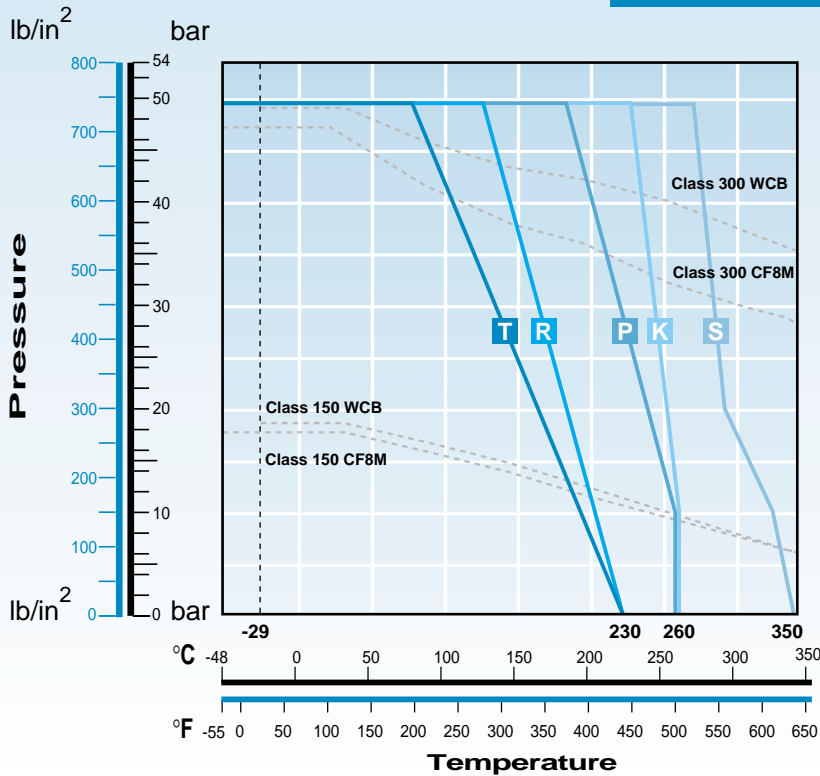

The pressure/ temperature rating is determined by the valve flanges and by the seat rating. Temperature ranges from -48°C to 300°C (-54°F to 572°F).

- T** Virgin PTFE
- R** Glass Filled PTFE
- P** Carbon Filled PTFE
- K** PEEK
- S** VESPEL

Other seats are available on request. Valves fitted with PEEK seats are assembled with PEEK thrust seal and SS 17-4PH stem.

Valve Options

HABONIM speciality with customer solutions for special applications has resulted in many designs. Some of the various valve designs and accessories that HABONIM have available with the 31P/32P series are shown below. For more information and other options, please consult with Habonim.

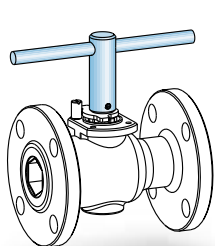

Extended Stem Handle
(See Bulletin C-514)

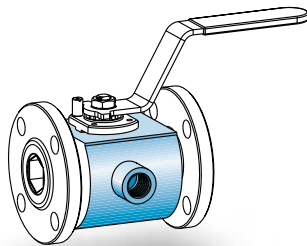

Steam Jacket
(See Bulletin C-511)

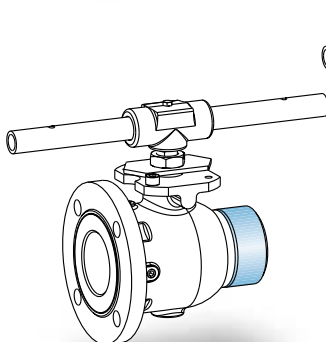

Butt weld End

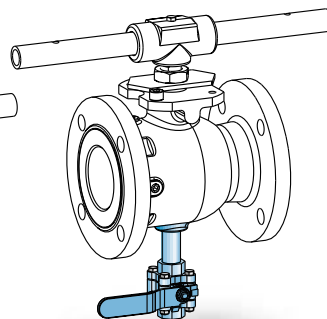

Double Block & Bleed

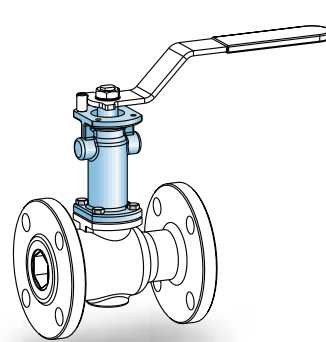

Fugitive Emission

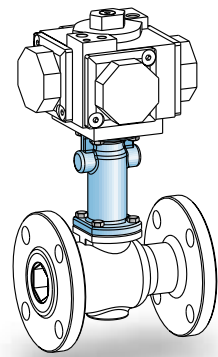

Fugitive Emission with Actuator

VALVE SIZE	Cv Values		Limiting Stem Input Torque*			
	FLOW COEFFICIENTS		316 S/S Stem material		17-4PH Stem material	
inch	Cv	Kv	Nm	in-lb	Nm	in-lb
1/2"	7	6	13.2	117	91	805
3/4"	10	9	13.2	117	91	805
1"	30	26	24.4	216	165	1,460
1 1/2"	90	78	48.6	430	268	2,372
2"	130	112	48.6	430	268	2,372
3"	350	302	385	3,400	1,930	17,000
4"	720	621	385	3,400	1,930	17,000
6"	1,020	879	1,570	13,900	7,500	66,300
8"	1,800	1,552	1,570	13,900	7,500	66,300

Cv - Flow in US GPM at 1 psi pressure drop.

Kv - Flow in m³/hr at 1 bar pressure drop.

Valve flow rates are determined in full open position with water at 15°C (60°F).

* Limiting Stem torque figures are based on random laboratory tests.

These are not to be confused with valve torque.

VALVE SPECIFICATION - 1/2" - 2" (15 - 50mm)

ITEM NO.	DESCRIPTION	MATERIAL SPECIFICATION
1	BODY	STAINLESS ST. ASTM A351 CF8M CARBON ST. ASTM A 216 WCB
2	INSERT	STAINLESS ST. ASTM A351 CF8M CARBON ST. ASTM A 216 WCB
3	BALL	STAINLESS ST. AISI 316
4	STEM	STAINLESS ST. AISI 316
*5	SEAT RING	VIRGIN PTFE
*6	BODY SEAL	VIRGIN PTFE
*7	STEM THRUST SEAL	25% CARBON FILLED PTFE
8	STOP PIN	STAINLESS ST. AISI 316
*9	GLAND PACKING	25% CARBON FILLED PTFE
10	GLAND	STAINLESS ST. 316
11	DISC SPRING	STAINLESS ST. 17-7PH
12	GLAND NUT	STAINLESS ST. AISI 316
13	TAB WASHER	STAINLESS ST. AISI 316
14	WRENCH	STAINLESS ST. AISI 304 CARBON ST. ZINC PLATED
15	SERRATED WASHER	STAINLESS ST. AISI 316
16	WRENCH NUT	STAINLESS ST. AISI 304
17	SLEEVE	VINYL PLASTISOL
18	PLUNGER SPRING	STAINLESS ST. AISI 302
19	ANTI STATIC PLUNGER	STAINLESS ST. AISI 316

The materials above are for standard applications. Other materials are available.
 * Standard items supplied in repair kits.

Locking Device Kit

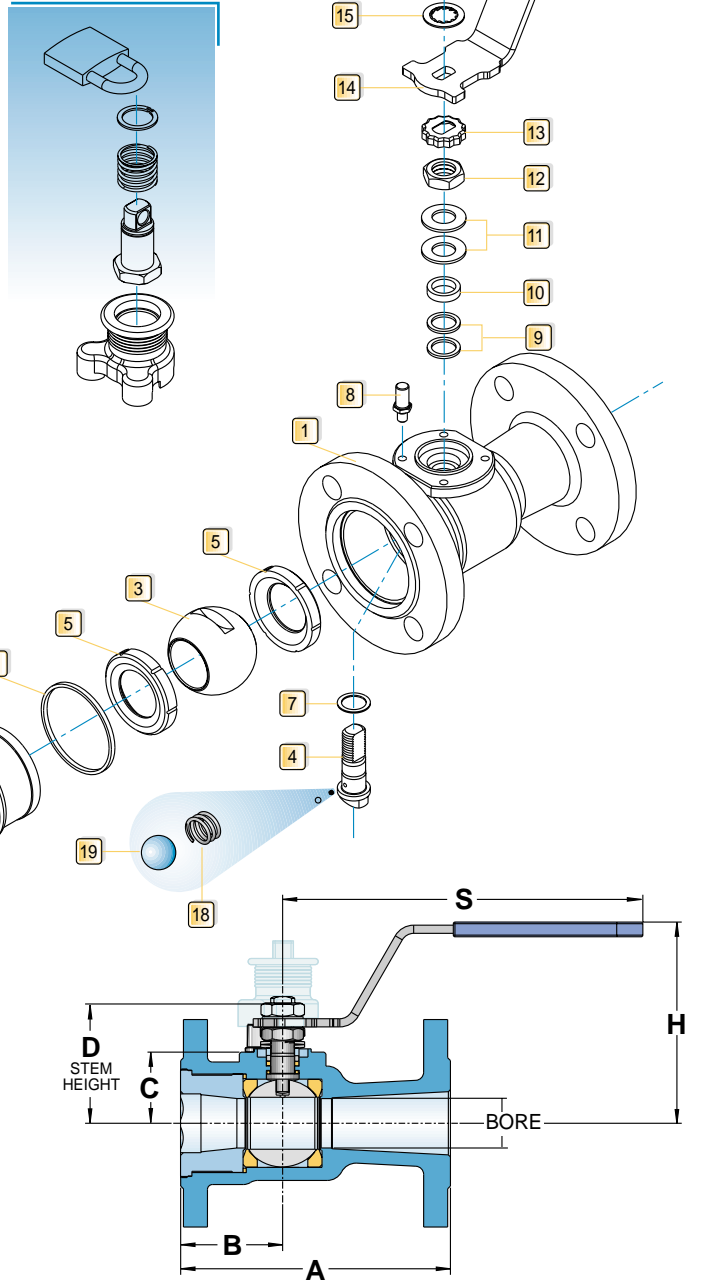

STEM DIMENSIONS

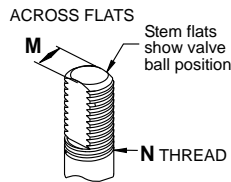

PREPARATION FOR ACTUATION

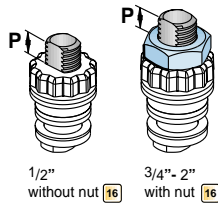

T THREAD
F PCD

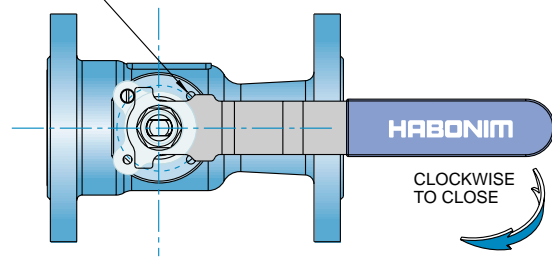

VALVE SIZE	BORE DIA	VALVE DIMENSIONS											APP. WEIGHT kg. / lb		
		A		B	C	D	H	S	M	N	P	F	150	300	
1/2"	mm	11.15	108.0	140	46.0	29.0	38.0	92.0	151.0	5.54	3/8"	11.1	36.0 (F03)	1.7	2.4
	in	0.44	4.25	5.5	1.81	1.14	1.5	3.62	5.94	0.218	UNF	0.437	1.42	3.8	5.3
3/4"	mm	14.3	117.0	152.0	49.3	31.4	40.3	94.0	151.0	5.54	3/8"	11.1	36.0 (F03)	2.3	3.3
	in	0.56	4.61	6.0	1.94	1.24	1.59	3.7	5.94	0.218	UNF	0.437	1.42	5.1	7.3
1"	mm	20.6	127.0	165.0	57.2	38.2	55.6	103.5	170.0	7.54	7/16"	15.4	42.0 (F04)	3.3	4.6
	in	0.81	5.0	6.5	2.25	1.50	2.19	4.07	6.69	0.296	UNF	0.606	1.65	7.3	10.2
1 1/2"	mm	31.8	165.0	190.0	62.3	43.6	73.1	119.2	220.5	8.7	9/16"	19.6	50.0 (F05)	5.5	8.7
	in	1.25	6.5	7.5	2.45	1.72	2.88	4.7	8.68	0.343	UNF	0.771	1.97	12.2	19.3
2"	mm	38.2	178.0	216.0	67.8	48.3	77.8	123.9	220.5	8.7	9/16"	19.6	50.0 (F05)	8.1	10.8
	in	1.50	7.0	8.5	2.67	1.90	3.06	4.88	8.68	0.343	UNF	0.771	1.97	18.0	24.0

VALVE SPECIFICATION 3" - 8" (80 - 200mm)

ITEM NO.	DESCRIPTION	MATERIAL SPECIFICATION
1	BODY	STAINLESS ST. ASTM A351 CF8M CARBON ST. ASTM A 216 WCB
2	INSERT	STAINLESS ST. ASTM A351 CF8M CARBON ST. ASTM A 216 WCB
3	BALL	STAINLESS ST. AISI 316
4	STEM	STAINLESS ST. AISI 316
*5	SEAT RING	VIRGIN PTFE
*6	BODY SEAL	VIRGIN PTFE
*7	STEM THRUST SEAL	25% CARBON FILLED PTFE
8	STOP PIN	STAINLESS ST. AISI 316
9	STEM LOCATION RING	STAINLESS ST. AISI 316
*10	GLAND PACKING	25% CARBON FILLED PTFE
11	GLAND	STAINLESS ST. 316
12	INDICATOR STOP PLATE	CARBON ST. ZINC PLATED
13	GLAND NUT	CARBON ST. ZINC PLATED
14	WRENCH HEAD	MALLEABLE IRON ZINC PLATED
15	WRENCH HANDLE	TUBE SCH. 40 ZINC PLATED
16	WRENCH BOLT	STAINLESS ST. AISI 304
17	INSERT RETAINING SCREW	STAINLESS ST. AISI 304 CARBON ST. ZINC PLATED
18	PLUNGER SPRING	STAINLESS ST. AISI 302
19	ANTI STATIC PLUNGER	STAINLESS ST. AISI 316

The materials above are for standard applications. Other materials are available.
 * Standard items supplied in repair kits.

Optional threaded Insert

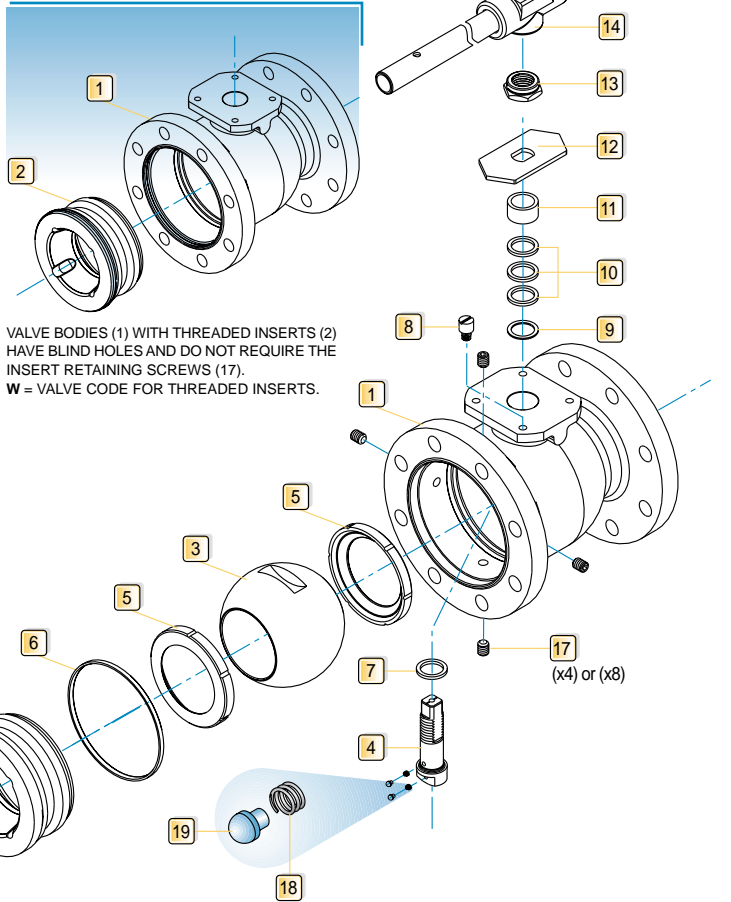

STEM DIMENSIONS

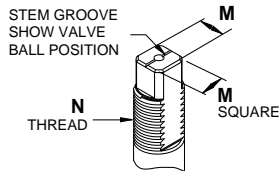

PREPARATION FOR ACTUATION

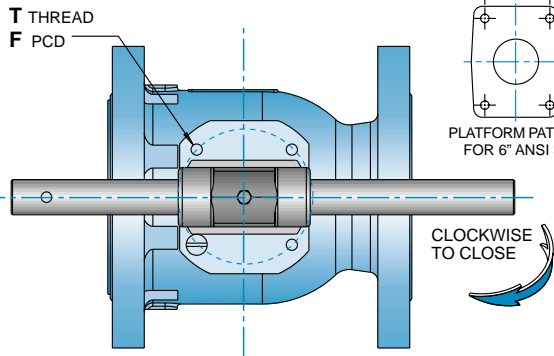
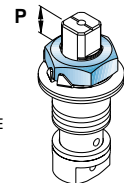

FIRESAFE BODY SEAL

S.ST. RING
PTFE SEAL
GRAPHITE BODY SEAL

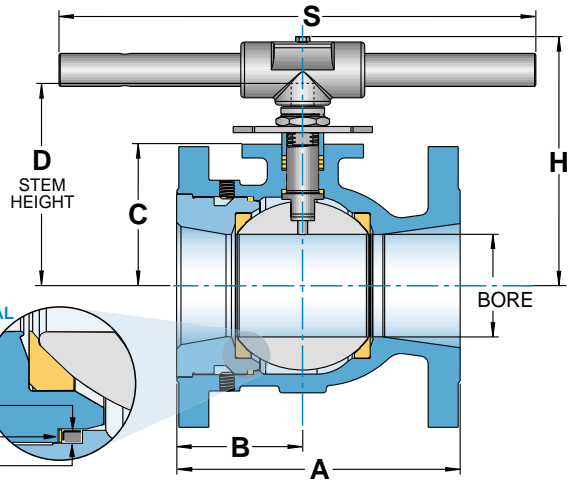

VALVE SIZE	VALVE DIMENSIONS												APP. WEIGHT kg. / lb			
	BORE DIA	A		B	C	D	H	S	M	N	P	F	T	150	300	
		150	300													
3"	mm	63.5	203	284	92.1	98.4	145	185.1	400	18.9	1"	16.7	102 (F10)	M10	18.0	22.7
	in	2.5	8.0	11.18	3.63	3.88	5.72	7.28	15.75	0.744	UNS	0.66	4.015		40.0	50.4
4"	mm	82.6	229	305	101.6	114.1	161	201	610	18.9	1"	16.7	102 (F10)	M10	28.2	36.3
	in	3.25	9.0	12.0	4.0	4.49	6.34	7.91	24.01	0.744	UNS	0.66	4.015		62.8	80.6
6"	mm	111.1	267	403	108.0	157.4	226	285.9	916	28.4	1 1/2"	26.2	*125 (F12)	M12	41.0	69.0
	in	4.38	10.5	15.88	4.25	6.20	8.91	11.25	36.08	1.12	UNS	1.03	4.921		91.0	153
8"	mm	144.4	292	419	163.5	185.2	254	313.6	916	28.4	1 1/2"	26.2	125 (F12)	M12	82.0	105
	in	5.68	11.5	16.5	5.37	7.30	10.0	12.34	36.08	1.12	UNS	1.03	4.921		182	233

* VALVE 6" ANSI 300 ONLY: X=76.2, Y=101.6

31P/32P Series Automated Valve Dimensions

Actuation

Where automation is required, the 31P/32P series ball valves are available with Habonim's unique 4-Piston pneumatic Compact actuator. The Compact actuator is available in 8 sizes, spring return or double acting. All the valves mounting flanges are according to ISO 5211 and are suitable for accommodating any quarter turn actuator (pneumatic or electric) for valve automatization. Valves can be operated for on-off or throttling application.

The actuators have a NAMUR air connection interface for attaching solenoids (except H15). Limit switches and positioners can be mounted on the actuator top face according to NAMUR or ISO bolt pattern. For information, please refer to Bulletin B-310.

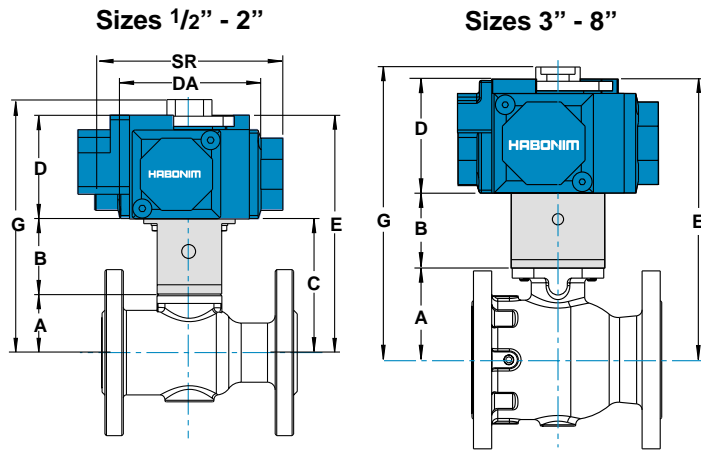

		31P/32P SERIES					COMPACT ACTUATOR		
VALVE SIZE	ACTUATOR SIZE	A	B	C	E	G	D	D/A	S/R
1/2"	H15		48	77	137	144.8	60.0	80.4	105.7
	F03	29.0	48	77	143.6	154.7	66.6	93.3	121.5
	H25		48	77	161.4	173.3	84.4	120.8	153.8
3/4"	H15		48	79.4	139.4	147.2	60.0	80.4	105.7
	F03	31.4	48	79.4	146	157.1	66.6	93.3	121.5
	H25		60	91.4	175.8	187.7	84.4	120.8	153.8
	H30		60	91.4	187.4	197.6	96.0	141.6	175.8
1"	H15		48	86.2	146.2	154	60.0	80.4	105.7
	F04	38.2	48	86.2	152.8	163.9	66.6	93.3	121.5
	H25		60	98.2	182.6	194.5	84.4	120.8	153.8
	H30		60	98.2	194.2	204.4	96.0	141.6	175.8
1 1/2"	H20		60	103.6	170.2	181.3	66.6	93.3	121.5
	F05	43.6	60	103.6	188	199.9	84.4	120.8	153.8
	H30		60	103.6	199.6	209.8	96.0	141.6	175.8
	H35		60	103.6	225.7	238.6	122.1	172.4	214.8
2"	H25		60	108.3	192.7	204.6	84.4	120.8	153.8
	F07	48.3	60	108.3	204.3	214.5	96.0	141.6	175.8
	H35		60	108.3	230.4	243.3	122.1	172.4	214.8
	H45		60	108.3	253.1	265.8	144.8	201.2	261.7
3"	H30		80	178.3	274.3	284.5	96.0	141.6	175.8
	F10	98.4	80	178.3	300.4	313.3	122.1	172.4	214.8
	H45		80	178.3	323.1	335.8	144.8	201.2	261.7
	H60		120	218.3	413.8	425.7	195.5	201.2	261.7
4"	H35		80	194.1	316.2	329.1	122.1	172.4	214.8
	F10	114.1	80	194.1	338.9	351.6	144.8	201.2	261.7
	H60		120	234.1	429.6	441.5	195.5	264.3	343.5
	H75		120	234.1	477.1	496.6	243.0	321.5	422.0
6"	H35		120	277.4	399.5	412.4	122.1	172.4	214.8
	F12	157.4	120	277.4	422.2	434.9	144.8	201.2	261.7
	H60		120	277.4	472.9	484.8	195.5	264.3	343.5
	H75		120	277.4	520.4	539.9	243.0	321.5	422.0
8"	H45		120	305.2	450	462.7	144.8	201.2	261.7
	F12	185.2	120	305.2	500.7	512.6	195.5	264.3	343.5
	H75		120	305.2	548.2	567.7	243.0	321.5	422.0

Actuator Sizing

Valve Sizing Tables of the Compact actuators on Habonim Valves are available on request. The sizing tables are based on valve size, differential pressure, valve seat types, working temperature, flowing media and frequency of operation. The valve torque figures are calculated from tests using water at room temperature at different pressure drops for each seat material and actuator air pressure. Please consult with HABONIM for more details.

Flanged Valve Sizing Table

The following sizing table is for Class 150 and 300 valves with PTFE seats at ambient temperatures and 10 bar pressure drop and is for reference only.

VALVE SIZE	Double Acting (DA)			Spring Return (SR)		
	60 psi	80 psi	100 psi	60 psi	80 psi	100 psi
1/2"	H15	H15	H15	H20-2A2B	H15-1B2	H15-2
3/4"	H15	H15	H15	H20-2A2B	H15-1B2	H15-2
1"	H20	H15	H15	H25-2A2B	H20-2C	H20-3
1 1/2"	H20	H20	H20	H30-2A2B	H25-2C	H25-3
2"	H25	H25	H20	H30-2A2B	H30-2C	H25-3
3"	H35	H30	H30	H45-2A2B	H35-2C	H35-3
4"	H45	H35	H30	H60-2A2B	H45-2C	H45-3
6"	H60	H45	H35	H75-2A2B	H60-2C	H60-3
8"	H75	H60	H45	CONSULT	H75-2C	H75-3

Mounting Actuators or Gear Operators

When preparing a valve for actuation, make sure to follow the instructions below.

Stem arrangement for actuated valves.

Valve sizes 1/2" to 2"

Release the wrench nut **1** and serrated washer **2**, remove the wrench **3** and refasten the wrench nut on the tab washer **4**. Remove the stop pin **5**. Valve size 1/2" and 2" do not require the wrench nut **1**.

Manual Valve stem assembly

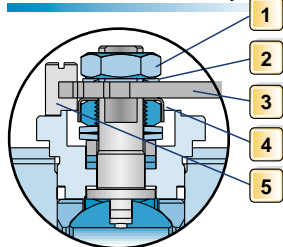

Actuated Valve stem assembly

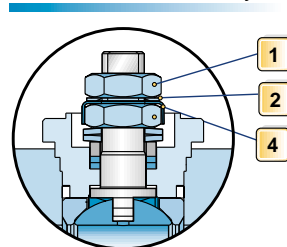

Valve sizes 3" to 8"

Release the wrench bolt **1** and remove the wrench handle **2**, wrench head **3**, gland nut **4** and stop plate **5**. Assemble the two disc springs **6**, stem location ring **7**, tab washer **8** and refasten the non-slotted gland nut **9**.

Manual Valve stem assembly

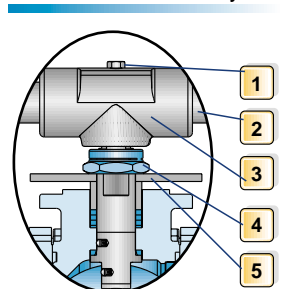

Actuated Valve stem assembly

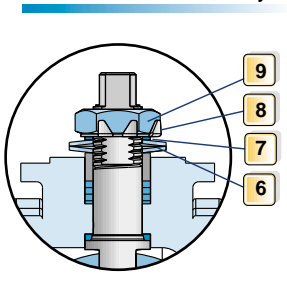

Locking Device

LLP (Locked in Last Position)

The Habonim spring loaded locking device (LD) is ideal for applications where it is critical to keep the valve position without the risk of accidental operation. The locking device fits easily to the valve stem by simply removing the stem nut and threading the lock stem above the handle. The LD can lock the valve in the closed or open position. The LD can be fitted to the valve in-line. Available in sizes 1/2" to 2".

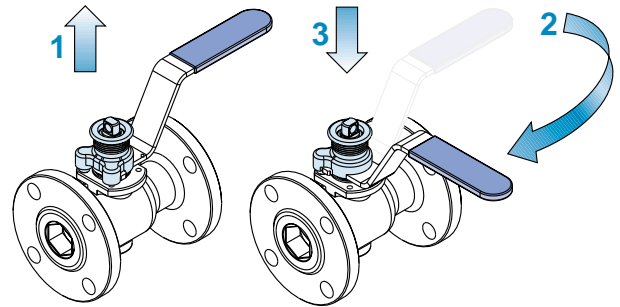

Valve in OPEN position Valve in CLOSED position

Antistatic Device

Antistatic device to discharge static electricity buildup on the ball, conforming to BS 5351 for continual electrical contact between ball/stem and stem/body. The contact is made by a spring loaded stainless steel element inserted in the stem or a conductive PTFE stem seal.

Valve sizes up to 2" require a stem/body contact, while larger size valves also need a ball/stem contact.

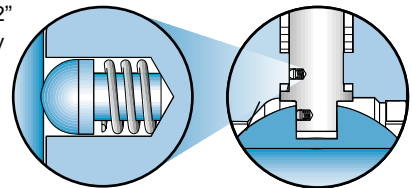

Valve Installation

Habonim flanged valves are delivered in the open position and with flange protection covers. Flanged valves are installed directly into the pipe line. When installing the valves in-line, follow the bolt tightening patterns shown below, using the recommended torque figures for safe operation. For more information, please refer to the Installation, Operation and Maintenance manual of the Habonim Flanged valves.

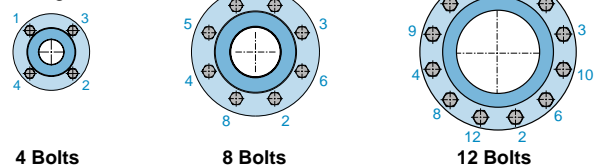

Valve Size (in)	Valve Size (DN)	ANSI 150		ANSI 300	
		Nm	in.lb	Nm	in.lb
1/2"	15	80	710	80	710
3/4"	20	80	710	140	1,240
1"	25	80	710	140	1,240
1 1/2"	40	80	710	240	2,120
2"	50	140	1,240	140	1,240
3"	80	170	1,500	250	2,210
4"	100	170	1,500	250	2,210
6"	150	170	1,500	250	2,210
8"	200	170	1,500	420	3,720

Identification Code

The HABONIM 31P & 32P Ball Valve Identification Code

1	2	3	4	5	6	7	8	9	10	11	12	13	14	15	16	17	18	19	20	21	22	23	24	25	26	27	28	29	30	
1	0		A	F	3	1	P	-	4	4	6	6	T	G	/	1	5	0												
SIZE		SERVICE			SERIES			BODY END			BALL STEM		SEAT SEAL		FLANGE			SPECIAL APPLICATION												
		31P or 32P																												

SIZE			SERVICE	BODY / END	SEAT	SEAL	SPECIAL APPLICATION
Code	Inch	mm		BALL / STEM			
05	1/2"	15	A Antistatic	1 Bronze	A TFM	G Expanded Graphite	90° Diverter ball valve 90° turn
07	3/4"	20	C Cryogenic	4 Carbon Steel	C PCTFE	I Impregnated Graphite	180° Diverter ball valve 180° turn
10	1"	25	D Diverter Bottom entry	6 S. St. 316 (L)	F PFA	M S. St O-Ring	A0866 Stem seal Ammonia service
15	1 1/2"	40	F Firesafe	7 Monel	H VX1	R Reinforced PTFE 15% Glass filled	P043 Stem seal for gas service
20	2"	50	K Dry Chlorine	8 S. St. 304	J Reinforced PTFE 25% Glass filled	T PTFE	F043 Stem seal Neoprene
30	3"	80	N Control	9 C. Steel LCB	K PEEK®	U UHMWPE	P250 Ball with Pressure relief hole
40	4"	100	O Oxygen	A Alloy-20	L Virgin PEEK®	V Viton®	J2N05 Jacketed valve, No. Outlets, Type, Size
60	6"	150	Q Cavity filler	C Hasteloy-C	M Metal	FLANGE	
80	8"	200	S Diverter Side entry	D Duplex	P NRG	150 ANSI 150 RF	V60 Control valve seat
			V Vacuum	M S. St. 17-4PH	R Reinforced PTFE 15% Glass filled	300 ANSI 300 RF	DBB Double Block & Bleed
			W Steam & Thermal fluid	Z Inconel 718	S VESPEL®	FF Flat Face	NACE Nace service
			X Metal seats		T PTFE	PN16 ANSI RF drilled to DIN	LD Swivel Locking device
					U UHMWPE	BW Buttweld neck	K LLP Locking device
					Y Delrin®		W Threaded Insert

In some applications the available options above are limited to specific sizes. Please consult with Habonim for details.

How to order

When placing an order for HABONIM valves, please provide as many details possible on the application such as: Media, Temperature, Pressure, Pipe line size and type of connection.

Example: 10 AF31P - 4466TG / 150-P250

Size 1" (10), Antistatic (A), Firesafe (F), Reduce Bore ANSI 150 (31P), C. St Body & Insert (4), S. St 316 Ball & Stem (6), PTFE Seats (T), Graphite Body Seals (G), ANSI 150 RF Flange (150), Ball with pressure relief hole (P250).

Standards of Compliance

Flanges:	ANSI B16.5 Raised Face BS 1560 class 150, 300
Face-to Face:	ANSI B16.10 Short Pattern
Antistatic:	BS 5351
Design:	Lloyds Type App. BS 5351 ANSI B16.34, BS 5159
Pressure Testing:	API 598. BS 6755 Pt. 1 ISO 5208
Fire Testing:	API 607 4th Edt. API 6F BS 6755 Pt. 2.
NACE (option must be specified)	MR-01-75-200
Quality Assurance Certification:	ISO 9001, PED 97/23/EC ISO -10474 DIN EN 10204 3.1.B

Quality Assurance

As an ISO 9001 certified, company Habonim operates according to internal manufacturing specifications that are written for each application and for specific customers. From the design stages to final inspection of assembled valves, Habonim controls its procedures for the integrity of the parts, their manufacturing process, storing and preservation and final assembly, to keep the highest standards of perfection of the product. All valves are 100% leak tested before packaging. Each valve is tagged for traceability and material certification is provided on request.

HABONIM 

INDUSTRIAL VALVES LTD
Kfar Hanassi, Upper Galilee 1 Israel
Tel : 9 7 2 - 4 - 6 9 1 4 9 1 1
Fax : 9 7 2 - 4 - 6 9 1 4 9 0 2
E-mail: habonim@habonim.co.il
www: habonim.com



ISSUE 00-06/02