

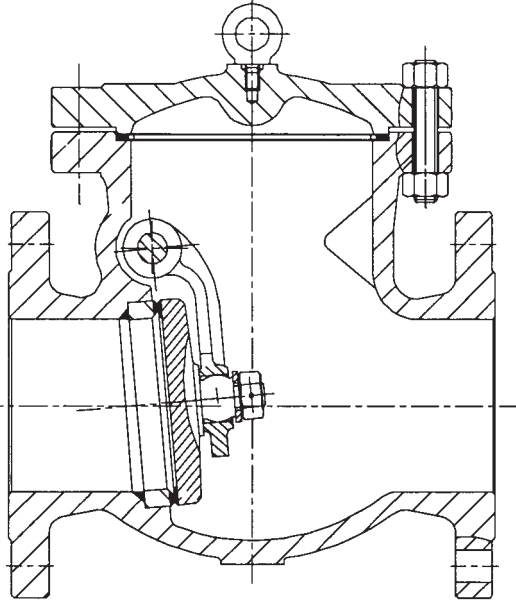

# BS 1868 CLASS 150 CHECK VALVES

## FIGURE NO: 3B01F



PARTS	MATERIALS
BODY	ASTM A216 GR WCB
COVER	ASTM A216 GR WCB
CLACK	ASTM A216 GR WCB WITH WELDED ASTM A182GRF6
BODY SEAT	ASTM A105 WITH STELLITE No 6
BODY BOLT	ASTM A194 GR B7
NUTS	ASTM A193 GR 2H
GASKET	304 SPIRAL WOUND WITH GRAPHITE FILLER

DESCRIPTION	SWING TYPE CHECK VALVE, BOLTED COVER.
DESIGN AND DIMENSIONS	BS1868.
PRESSURE TEMPERATURE RATINGS	ANSI B16.34
FACE TO FACE DIMENSIONS	ANSI B16.10.
CONTACT FACES	MSS SP-6 SERRATED OR SMOOTH FINISH
FLANGE DIMENSIONS	ANSI B16.5
MARKING	MSS SP 25
MANUFACTURED TO	ISO 9000.
OTHER	LIFTING RING ON SIZES $\geq 4"$ . UNDRILLED & PN16 FLANGES.

Size	in	2"	2½"	3"	4"	5"	6"	8"	10"	12"	14"	16"	18"	20"	24"
	mm	50	65	80	100	125	150	200	250	300	350	400	450	500	600
Face to Face	in	8	8.5	9.5	11.5	13	14	19.5	24.5	27.5	31	34	38.5	38.5	51
	mm	203	216	241	292	330	356	495	622	698	787	864	978	978	1295
Centre to top	in	5.7	6.1	6.6	7.7	8.25	9.4	11.1	13.5	15.7	18.3	19.5	22.8	23.2	27.4
	mm	144	156	168	195	210	238	283	344	400	464	495	579	588	695
Weight	kg	14	27	30	48	66	83	168	231	319	480	640	682	758	1252

