

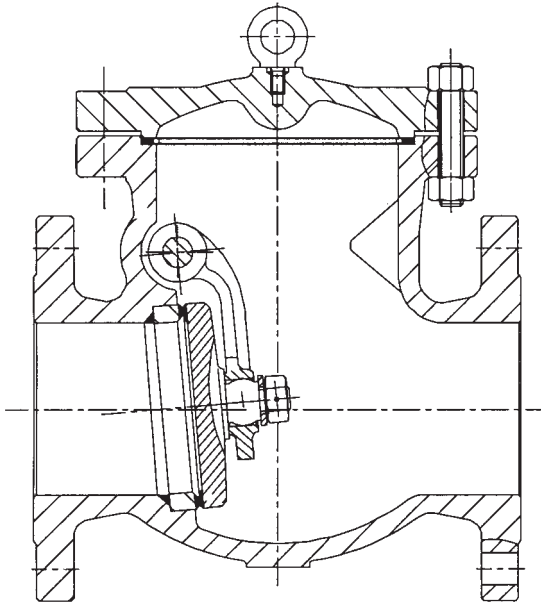

BS 1868 CLASS 300 CHECK VALVES

FIGURE NO: 3B03F



PARTS	MATERIALS
BODY	ASTM A216 GR WCB
COVER	ASTM A216 GR WCB
CLACK	ASTM A216 GR WCB WITH WELDED ASTM A182 GR F6
BODY SEAT	ASTM A105 WITH STELLITE No 6
BODY BOLT	ASTM A194 GR B7
NUTS	ASTM A193 GR 2H
GASKET	304 SPIRAL WOUND WITH GRAPHITE FILLER

DESCRIPTION	SWING TYPE CHECK VALVE, BOLTED COVER.
DESIGN AND DIMENSIONS	BS1868.
PRESSURE TEMPERATURE RATINGS	ANSI B16.34.
FACE TO FACE DIMENSIONS	ANSI B16.10.
CONTACT FACES	MSS SP-6 SERRATED OR SMOOTH FINISH.
FLANGE DIMENSIONS	ANSI B16.5.
MARKING	MSS SP 25.
MANUFACTURED TO	ISO 9000.
OTHER	LIFTING RING ON SIZES $\geq 4"$. UNDRILLED FLANGES.

Size	in	2"	2½"	3"	4"	6"	8"	10"	12"	14"	16"	18"	20"	24"
	mm	50	65	80	100	150	200	250	300	350	400	450	500	600
Face to Face	in	10.5	11.5	12.5	14	17.5	21	24.5	28	33	34	38.5	40	53
	mm	267	292	318	356	444	533	622	711	838	864	978	1016	1346
Centre to Top	in	6.3	7	7.6	8.7	11	13.2	15	17.3	19.7	21.3	22	23.6	29.9
	mm	160	177	194	222	280	336	380	440	500	540	560	600	760
Weight		25	44	49	78	140	244	360	519	655	1100	1450	1860	3000

