

TYPE 2500 SAFETY RELIEF VALVE

The **Type 2500 Relief/Safety Relief valves** are designed to have a short 'simmer', then to open rapidly to the full open position, and to re-seat at a controlled pressure. When the valve is in its fully lifted position, the discharge area is controlled by the bore of the nozzle, which ensures that flow calculations for various mediums can be reliably made.

Valves are supplied in sizes 1" x 2" to 8" x 10", orifices D through to T and can be manufactured in Cast Steel, Stainless Steel and any other materials to suit the application, with flanges to customers requirements.

Valves can also be supplied with a packed lever or open lever lifting device, limit switch to indicate opening and closing of the valve, governing ring to limit adjustment of the spring to the set point, for ease of re-setting, balanced bellows when there is a variable back pressure.

Installation: During installation of the valve avoid bumping or shaking to prevent damaging the flange faces and misalignment of the trim. Blow through the circuit line on which the valve is to be installed, this is to remove any foreign bodies. Clean the valve and nozzle connections thoroughly; foreign bodies on the nozzle may damage the valve seat during popping. Install the valve in a vertical position only, with the inlet downwards. After the valve has been installed make it pop at least twice to allow automatic alignment of the trim. Misalignment may be caused accidentally during transport or during installation.

Maintenance: The most frequent operation to be carried out is a

precise check, made a regular intervals, to observe whether any obvious faults exist in the different parts of the valve. It should be checked first of all that there are no leakages; these must always be avoided, especially when the medium is poisonous, highly volatile or very expensive. Carry out periodic venting for valves with a lifting device to check regular operation. During these tests the pressure must be at least 75% of the full working pressure.

Overhaul: To Overhaul the valve the following procedure should be followed: remove the cap, mark the position of the adjusting screw relevant to the locknut, so the correct position may be found during re-setting. Loosen the adjusting screw and locknut to relax the spring, remove the clampscrew from the body. Using a screwdriver, move the blowdown ring until it touches the disc holder (moving From left to right) taking care to count and note the number of notches to regain the same position when re-setting. Remove the bonnet from the body by unscrewing the nuts. Remove the upper spring carrier, spring and lower spring carrier from the spindle. Using the spindle as a handle, pull out the whole unit from inside. Remove pin and unscrew the stem from the disc holder. Remove stem from the guide. Remove disc from the disc holder, place the disc holder on a wooden surface and drive the disc out downwards. Unscrew the blowdown ring in an anticlockwise direction. Remove the nozzle from the body. Check the contact faces of the seat and disc, should any scratching or pitting be present the surfaces will need to be relapped. Replace all of the joints then assemble the valve in reverse order. To prevent damage to the disc and nozzle faces, place a screwdriver in the spindle slot. This will stop the spindle turning whilst re-setting the valve.

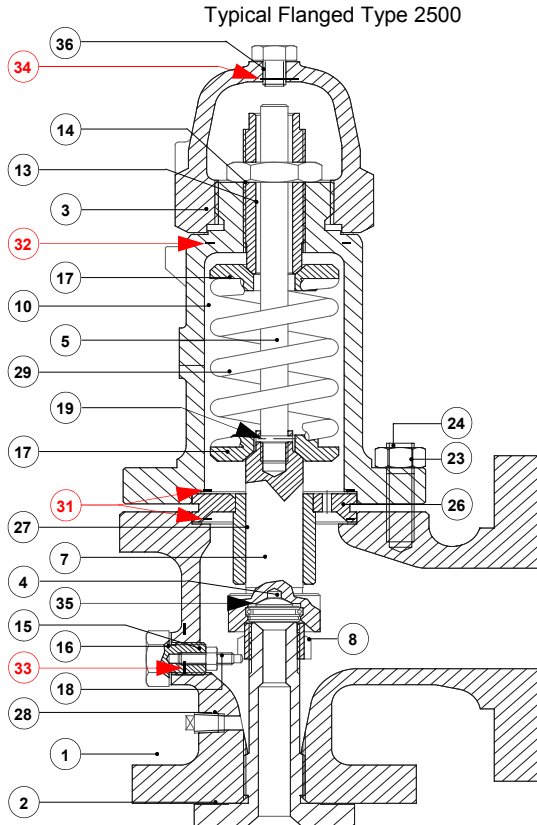

Item	Description	Material (C/S)	Material (S/S)
1	Body	Carbon Steel	Stainless Steel
2	Nozzle	Stainless Steel	Stainless Steel
3	Cap	Carbon Steel	Stainless Steel
4	Disc	Stainless Steel	Stainless Steel
5	Spindle	Stainless Steel	Stainless Steel
7	Disc Holder	Stainless Steel	Stainless Steel
8	Blowdown Ring	Stainless Steel	Stainless Steel
10	Bonnet	Carbon Steel	Stainless Steel
13	Adjusting Screw	Stainless Steel	Stainless Steel
14	Locknut	Stainless Steel	Stainless Steel
15	Screwed Pin	Stainless Steel	Stainless Steel
16	Clampscrew	Stainless Steel	Stainless Steel
17	Spring Carrier	Carbon Steel	Stainless Steel
18	Locknut	Stainless Steel	Stainless Steel
19	Pin	Stainless Steel	Stainless Steel
23	Stud	Carbon Steel	Stainless Steel
24	Nut	Carbon Steel	Stainless Steel
26	Guide Flange	Carbon Steel	Stainless Steel
27	Guide Tube	Stainless Steel	Stainless Steel
28	Drain Plug	Stainless Steel	Stainless Steel
29	Spring	Carbon Steel	Stainless Steel
31	Joint, Guide	Non Asbestos	Non Asbestos
32	Joint, Cap	Non Asbestos	Non Asbestos
33	Joint, Clampscrew	Non Asbestos	Non Asbestos
34	Joint, Plug	Non Asbestos	Non Asbestos
35	Circlip, Disc	Stainless Steel	Stainless Steel
36	Plug	Stainless Steel	Stainless Steel

These Items are recommended spares.

TYPE 2500 RELIEF/SAFETY RELIEF VALVE

Numbering System Code

To simplify the selection and specifying of Safety Relief Valves, a numbering system is used in which the digits have a distinct significance.

Examples:-

1. A 2" ANSI 300 Inlet x 3" ANSI 150 Outlet, cast steel body, stainless steel trim with 'J' orifice, carbon steel spring, fitted with bellows and packed easing lever, closed bonnet, without test gag.
The valve number would be:- **2531J-CB-020**.
2. A 4" ANSI 150 Inlet x 6" ANSI 150 Outlet, all stainless steel construction with 'P' orifice, no bellows, no easing lever, closed bonnet, fitted with a gag.
The valve number would be:- **2511P-SN-001**.

A breakdown of the numbering system is listed below:-

The first and second digit indicate the valve series.

25	2500 and 2500/F
26	2600

The third and fourth digit identify inlet and outlet ratings respectively for flanged valves.

The fifth digit identifies the orifice for flanged valves.

Third Digit	Inlet Rating (ANSI)
1	150
3	300
5	600
6	900
7	1500
8	2500

Fourth Digit	Outlet Rating (ANSI)
1	150
2	300

* The values of the areas indicated on the table are the effective ones taken during the approval phase by ANCC.

Fifth Digit	Orifice Area *		Fifth Digit	Orifice Area *	
	In ²	Cm ²		In ²	Cm ²
D	0.121	0.785	L	3.115	20.109
E	0.215	1.389	M	3.927	25.339
F	0.335	2.164	N	4.730	30.581
G	0.547	3.530	P	6.970	45.007
H	0.855	5.515	Q	12.060	77.913
J	1.405	9.079	R	17.420	112.663
K	2.003	12.946	T	28.400	183.281

The sixth digit identifies the body, bonnet and spring materials.

Disclaimer

The information, specifications and technical data contained in this catalogue are subject to change without notice. The user should verify all technical data and specifications prior to use. Broady Valves does not warrant that the material and information contained herein is current or correct and assumes no responsibility for the use or misuse of any such material and information by the user.

	Body and Bonnet	Spring
C	Carbon Steel A216 WCB	Carbon Steel
S	Stainless Steel A351 CF8M	Stainless Steel
A	Alloy Steel A217 WC6	Tungsten Steel
B	Aluminium Bronze BS1400 AB2	Stainless Steel
G	Gunmetal BS1400 LG2	Stainless Steel
L	Alloy Steel A352 LC1	Stainless Steel
T	Carbon Steel A216 WCB	Tungsten Steel

The seventh digit indicates the type of construction.

The eighth digit indicates whether the bonnet is open or closed.

N	Standard
B	Balanced Bellows

The ninth digit identifies the lifting device.

0	Closed
1	Open

The tenth digit refers to the test gag.

0	None
1	Open Lever
2	Packed Lever

0	Without test gag
1	With test gag



Broady Valves Limited
 English Street, Kingston upon Hull,
 East Yorkshire, HU3 2DU, United Kingdom
 Telephone: 01482 619601 Facsimile: 01482 619701
 Email: sales@broady.co.uk Website: www.broady.co.uk

