

TYPE 4 PRESSURE RELIEF VALVE

The **Type 4 inline pressure relief valves** are designed to automatically discharge the excess process medium, so as to prevent a predetermined safe pressure being exceeded. They are suitable for use on compressed air, gas, water, oil and steam. These valves are used in a variety of applications throughout industry, where their outstanding accuracy and reliability have been proven.

Valves are supplied in sizes ½" to 8" in Gunmetal, Aluminium Bronze, Stainless Steel and Carbon Steel. With ends screwed female or alternatively flanged to customers requirements. The maximum set pressure is 21.0 Barg. **(Consult Broady Technical Sales Engineers for further information).**

Specification

All valves are supplied with a nitrile disc for air, gases, water, oils, etc., but other materials are available on request. Valves for steam and high pressure service are supplied with a metal to metal valve lid.

Description of Action

Pressure is admitted to the underside of the valve lid until

the force on the valve lid matches that of the spring load. As the pressure force increases beyond that of the spring load the valve will open, allowing the medium to be discharged. When the pressure falls below that of the set pressure, the spring force becomes dominant which results in the valve closing. The set pressure can be varied to requirements by compressing or relaxing the spring. The adjusting screw is provided for this purpose.

Compressing the spring **increases** the set pressure, **relaxing** the spring **decreases** the set pressure.

Maintenance : Periodically the valve lid and seat should be examined, if the contact faces are marked they should be refaced and lapped in, if the soft seat is damaged it should be replaced. The spring should be examined for any deterioration, such as cracking, thinning of the coils or reduction in length. The spring should be replaced if any defect is found. All parts should move freely in their respective guides. All valves should be fitted in a horizontal pipeline, with flow in the direction of the arrow cast on the side of the body. The adjusting screw should be directly above the pipeline. The pipe must be clean and free from dirt, scale, etc.

Typical Gunmetal Assembly

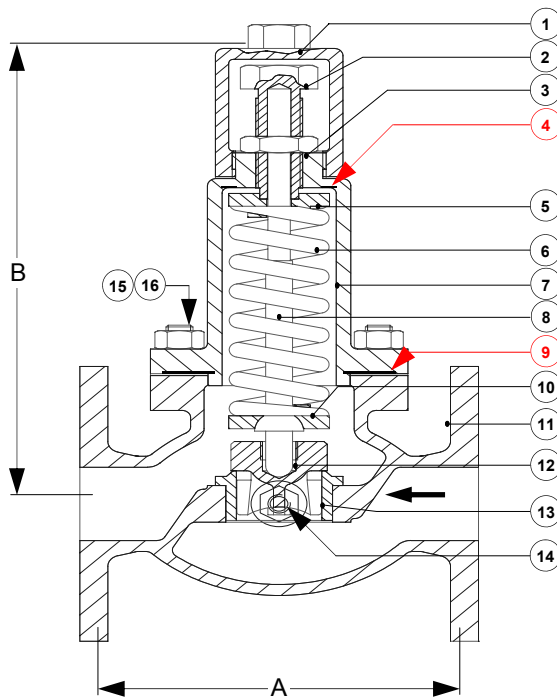

Item	Description	Material
1	Bonnet	Gunmetal
2	Adjusting Screw	Aluminium Bronze
3	Locknut	Aluminium Bronze
4	Joint, Bonnet	Non Asbestos
5	Upper Spring Carrier	Aluminium Bronze
6	Spring	Stainless Steel
7	Dome	Gunmetal
8	Spindle	Aluminium Bronze
9	Joint, Dome	Non Asbestos
10	Lower Spring Carrier	Aluminium Bronze
11	Body	Gunmetal
12	Valve Lid	Gunmetal
13	Seat	Aluminium Bronze
14	Seat Securing Screw	Aluminium Bronze
15	Stud	Aluminium Bronze
16	Nut	Aluminium Bronze

Size	* A *	B
15NB	115	138
20NB	115	138
25NB	140	213
40NB	179	260
50NB	229	308
65NB	259	341
80NB	272	415
100NB	330	460
125NB	328	560
150NB	470	660
200NB	519	851

Disclaimer

The information, specifications and technical data contained in this catalogue are subject to change without notice. The user should verify all technical data and specifications prior to use. Broady Valves does not warrant that the material and information contained herein is current or correct and assumes no responsibility for the use or misuse of any such material and information by the user.

* This dimension is for Gunmetal ANSI150 FF flanges only. Where flange thickness differs from Gunmetal ANSI150 FF, the face to face should be adjusted accordingly.

These Items are recommended spares.



Broady Valves Limited
 English Street, Kingston upon Hull,
 East Yorkshire, HU3 2DU, United Kingdom
 Telephone: 01482 619601 Facsimile: 01482 619701
 Email: sales@broady.co.uk Website: www.broady.co.uk

